

Heat Integration of a Hydrogen Production System With Simplistic Copper-Chlorine (Cu-Cl) Thermochemical Cycle*

Wei Wu^{*}, Wijayanti Felicia

Abstract— The Cu-Cl thermochemical cycle for hydrogen production was selected on the basis of its high efficiency and moderate temperature requirements. The modeling and simulation of Cu-Cl thermochemical cycle for hydrogen production is investigated in Aspen Plus. Since this cycle is a high energy-consuming process, the heat integration technique is implemented to recover the waste heat such that the process optimization can be successfully achieved. The result confirms that the optimal heat integration has contribution in achieving the maximum heat recovery and reducing the capital and operating cost.

I. INTRODUCTION

The dependence of modern civil society on the unrenewable energy sources, such as petroleum, natural gases, and coal has become a serious problem nowadays regarding the climate change and green-house gas emission then has resulted in wide research and development on the alternative, clean, and sustainable energy sources. Hydrogen production powered by nuclear energy is one of the attractive energy source which has potential to be sustainable and can be produced using many processes which are already commercialized, such as coal gasification, water electrolysis using electricity, and steam methane reforming (SMR) [1]. Nevertheless, alternative processes are under development. Water splitting via thermochemical cycle using copper-chlorine (Cu-Cl) is a promising process to decompose water into its components, hydrogen and oxygen, through intermediate copper and chlorine compounds, with the inputs merely water and nuclear-derived heat. The process does not give any contribution to greenhouse gas emission and have implication with a series of close loop chemical reactions [2] with lower temperature requirement than the other thermochemical processes [3]. Cu-Cl cycle has not been built up yet, however many studies have been conducted and are available in the literature.

The findings of the current study by Lewis et al. [4,5] who found that the Cu-Cl thermochemical cycle is a viable and feasible process regarding to engineering and energy efficiency. The simulation was developed using Aspen Plus software and hydrogen production cost was estimated to be \$3.30/kg of H₂. Naterer et al. [6] presented the recent Canadian advances in nuclear-based hydrogen production

and the thermochemical Cu-Cl cycle. They listed recent development with aspects of individual process and reactor developments within the Cu-Cl cycle, the thermochemical properties, materials, controls, safety, reliability, economic analysis of electrolysis at off-peak hours, and plant integration with Canada nuclear plants. Zamfirescu et al. [7] investigated the thermophysical properties of copper compounds in the Cu-Cl cycle and the kinetics of the copper/hydrochloric acid reaction in the Cu-Cl cycle were evaluated [8].

Conceptual process using Aspen Plus software by Rosen et al. [9] indicated that the total heat requirement for hydrogen production via Cu-Cl cycle was 543.7 kJ/mol H₂ and the energy efficiency was 52.57%. Jaber et al. [10] studied heat recovery from molten Cu-Cl in the Cu-Cl cycle. They examined the convective heat transfer between molten Cu-Cl droplets and air in a counter-current spray flow heat exchanger.

The issues of global warming and greenhouse gas emissions are considered as energy-related problems [11], the heat exchanger network (HEN) technique is important for energy integration which has been satisfactorily developed to solve various chemical processes. Posada and Manousiouthakis [12] showed that the heat integration of SMR process could result in a 36% reduction in utility costs with respect to a conventional process. Similarly, the HEN method has been successfully implemented to many industrial plants, e.g. an industrial ethylbenzene plant [13] and an ethyl alcohol plant [14].

Inspired by the study of copper chlorine thermochemical cycle to produce hydrogen, a new configuration for the Cu-Cl cycle is developed. Three-step Cu-Cl cycle is introduced where the steady state simulation is designed and analyzed using Aspen Plus chemical process simulation package. Energy efficiency of the process are examined. The heat exchanger network (HEN) design and pinch analysis are employed to achieve the maximum heat recovery of the three-step Cu-Cl cycle such that the hot/cold utility loads can be saved by over 80%. Finally the minimum annual total cost near the pinch is estimated.

II. SYSTEM DESCRIPTION

Figure 1 consists of three major reactions, the details are presented in Table 1. The cycle involves three steps, which are hydrolysis reaction, electrolysis, and hydrogen production. Fig. 1 showing the simulation input only water and nuclear-derived heat enter the cycle while the output only hydrogen and oxygen without green-gas emissions. Liquid water at room temperature enters the cycle through several heat exchangers where it is evaporated until the temperature becomes 600°C.

*Research is supported by Ministry of Science and Technology of Taiwan.

Wei Wu is with the National Cheng Kung University, Tainan 70101, Taiwan (Tel.: +886-6-2757575; fax: +886-6-2344496; e-mail: weiwu@mail.ncku.edu.tw).

Wijayanti Felicia is with the Chemical Engineering Department, National Cheng Kung University, Tainan 70101, Taiwan (e-mail: fc_bellissima@yahoo.com).

TABLE I. THE THREE STEPS CU-CL THERMOCHEMICAL CYCLE WITH THEIR CORRESPONDING REACTION AND OPERATING TEMPERATURE

Step	Reaction	T (°C)
1	$2\text{CuCl}_2(\text{aq}) + 2\text{H}_2\text{O}(\text{g}) \rightarrow \text{CuCl}(\text{l}) + 2\text{HCl}(\text{g}) + 0.5\text{O}_2(\text{g})$	600
2	$4\text{CuCl}(\text{s}) \rightarrow 2\text{CuCl}_2(\text{aq}) + 2\text{Cu}(\text{s})$	25
3	$2\text{Cu}(\text{s}) + 2\text{HCl}(\text{g}) \rightarrow 2\text{CuCl}(\text{l}) + \text{H}_2(\text{g})$	450

Steam and copper chlorine come into the hydrolysis reactor where the chemical reaction occurs. The reaction is as follows :

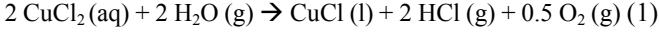

This is an endothermic reaction which yields hydrogen chloride gas (HCl), oxygen gas, and liquid copper monochloride (CuCl). Furthermore, liquid copper monochloride passes some coolers to be solidified into 25°C then enters the electrolysis chamber, where the reaction is as follows :

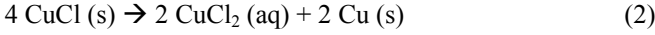

This is an endothermic reaction which yields aqueous copper chlorine and solid copper. The solid copper and hydrogen chlorine gas come into the hydrogen production chamber whose temperature has been adjusted previously to that steps's operating temperature. The operating temperature for the third step is 450°C and the reaction is as follows:

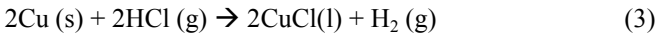

The products of this reaction are hydrogen gas (H₂) and liquid copper monochloride (CuCl).

The kinetic model proposed by Serban et al. [15] and Zamfirescu et al [8,15] for reaction (1) and (3) are:

$$k_f = 1737573.23 \exp(-7515.5/T) \text{ h}^{-1} \quad (4)$$

$$k (\text{min}^{-1}) = 2.9 \times 10^{-7} \exp(-24.4/RT) \quad (5)$$

In attempt to determine the potential of the Cu-Cl cycle, the flowsheet of experiment was conducted using an Aspen Plus software. According to the specifications of two coolers and three heaters in Table 2, the heating and cooling load of the system without heat integration are 1241970 kcal/h and 1325300 kcal/h.

III. HEAT INTEGRATION

The heat integration by using pinch analysis were chosen in order to address the system with minimum energy requirement and maximum waste heat recovery. In Fig.1, we can see that the most important aspect needed are not only extra energy, but also heaters and coolers to adjust the inlet and outlet temperatures. Thus, the heat exchanger network (HEN) were optimized to address the optimal heat integration design so that some energy targets could be achieved. The targets included the area and number of heat exchangers and the duties of external hot or cold utilities.

A. Pinch Point Analysis

Based on the mass flowrate and temperature of hot and cold streams in Fig. 1, the formula of the minimum number of heat exchangers (U_{\min}) and the total network area (A_{total}) are described as follows: [16]

TABLE II. THE SPECIFICATION OF HEATERS AND COOLERS

Unit	Duty (kcal/h)	T in (°C)	T out (°C)
C1	1.223 E6	25	600
C2	1.897 E4	25	600
H1	2.21 E5	600	25
H2	8.83 E5	600	450
H3	2.213 E5	450	25

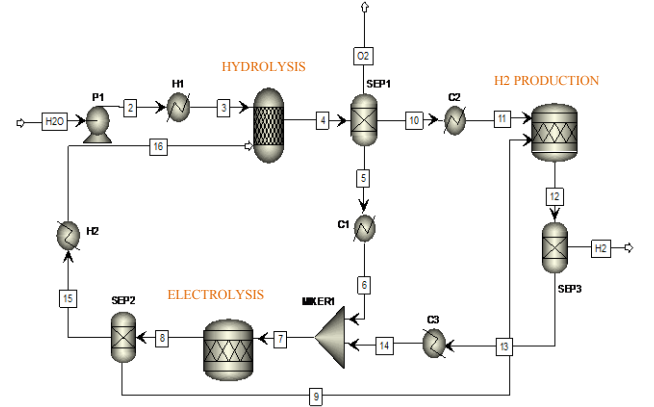

Figure 1. Aspen Plus process flowsheet of the simplistic three-step Cu-Cl thermochemical cycle

$$U_{\min} = N - 1 \quad (6)$$

$$A_{\text{total}} = \frac{1}{U} \sum_{k=1 \dots K} \text{Interval} \frac{\Delta H_k}{\Delta T_{\text{LM},k}} \quad (7)$$

Where N is the total number of streams (including utilities). $\Delta T_{\text{LM},k}$ represents the log mean temperature difference at the prescribed segment k. K represents the number of segments, and the heat transfer coefficient $U = 0.1 \text{ kJ}/(\text{h} \cdot \text{m}^2 \cdot \text{K})$ is assumed to be the same for all streams. By eq. (6) and (7), the number of heat exchangers for the system heat recovery at the pinch is estimated to be 6 and the corresponding surface area is estimated to be 317.1 m².

B. Heat Exchanger Network (HEN)

Aspen Energy Analyzer was used to developed the optimal heat exchanger network (HEN) framework near the pinch point where multiple shells and stream splitting are taken into account. Fig. 2 shows that there are two heat exchangers (white matches) which are used to carry out internal heat recovery, two heat exchangers (red matches) to adjust temperatures of two cold streams from hot utility, and two heat exchangers (blue matches) to adjust temperatures of two hot streams from cold utility. Based on the specifications of six matches of heat exchangers in Table 3, the total area is 111.397 m², and the heating and cooling load from external utility are 142370 kcal/h and 226508 kcal/h.

C. Cost Evaluation

To identify the cost evaluation of the heat integration the term annual capital cost, the annual operating cost, and the annual total cost are used. The formulas are as follows:

- (i) Annual operating cost = costs of hot and cold utilities
- (ii) Hot or cold utility cost = $\dot{m}C_p\Delta T * \text{cost index}$
- (iii) Annual capital cost = costs of heat exchanger and fired heater

$$\text{Cost of heat exchanger} = a + b \times \left(\frac{A_s}{N_{sh}}\right)^c \times N_{sh} \quad (8)$$

$$\text{Cost of fired heater} = a + b \times (\text{heat duty})^c \quad (9)$$

(iv) Annual total cost = annual op. cost + annual cap. cost

where N_{sh} represents the number of shell and A_s is the total network area. We assume $N_{sh} = 22$ while a , b , and c are specified by Aspen Energy Analyzer, e.g., $a = 10,000$, $b = 800$ and $c = 0.8$ in Eq. (8) and $a = 100,000$, $b = 1000$ and $c = 0.8$ in Eq. (9). According to Corripio et al. [18], parameter a and b are the coefficient values used to calculate the design pressure cost factor. They depend on the operating pressure of heat exchanger. Meanwhile, parameter c is the coefficient value used to calculate the based cost of heat exchanger and it depends on the heat exchanger construction material [19]. Therefore, the cost evaluation can be seen in Fig. 3. The rate of return (ROR) = 10% and plant life (PL) = 5 year are considered.

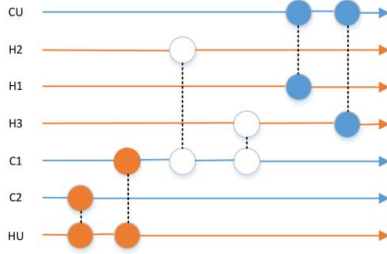

Figure 2. Heat exchanger network

TABLE III. THE SPECIFICATIONS OF HEAT EXCHANGER NETWORK

Match	Exchanger duty (kCal/h)	Area (m ²)	Hot Stream		Cold Stream	
			T _{in} (°C)	T _{out} (°C)	T _{in} (°C)	T _{out} (°C)
Cu-H1	2.213 e5	6.524	600	25	-24.99	-24
Cu-H3	2179	0.2663	35	25	-25	-24.99
HU-C1	2.491 e5	9.959	1879	545.5	482.8	600
HU-C2	1.897 e4	0.1901	2000	1897	25	600
C1-H2	8.830 e5	45.76	600	450	67.52	482.8
C1-H3	9.041 e4	10.28	450	35	25	67.52

TABLE IV. THE PARAMETERS OF HOT AND COLD UTILITIES [17]

Utility	T _{in} (°C)	T _{out} (°C)	Cp (kJ/kg.C)	Cost index (\$/kcal)
Fire heater	2000	1864.4	1.000	2.653 e-05
Propane	-25	77	4.000	1.145 e-05

IV. DISCUSSION

The pinch point analysis shows the maximum heat recovery of the process. Within HEN framework, the utility load for heating and cooling can be reduced to 89.25% and 81.76%. The efficiency of the heating load is :

$$\eta_{\text{heating}} = \left(1 - \frac{142370 \frac{\text{kcal}}{\text{h}}}{1241970 \frac{\text{kcal}}{\text{h}}}\right) * 100\% = 89.25\% \quad (10)$$

And the efficiency of cooling load is :

$$\eta_{\text{cooling}} = \left(1 - \frac{226508 \frac{\text{kcal}}{\text{h}}}{1325300 \frac{\text{kcal}}{\text{h}}}\right) * 100\% = 81.76\% \quad (11)$$

By applying the matches of heat exchanger network in Fig. 2, the heat-integrated system is depicted in Fig. 3. The hot utility through two matches (HU-C2 and HU-C1) increase the

temperature of one of streams from 482.8°C to 600°C which also covers the heat requirement for hydrolysis reaction and hydrogen production reaction. The cold utility through two matches (CU-H1 and CU-H3) decrease the temperature of CuCl stream from hydrogen production reactor from 35°C to 25°C, and then cools down the outlet temperatures of CuCl from hydrolysis chamber to the normal temperature. Liquid water is also preheated through two internal heat exchangers (C1-H3 and C1-H2). These internal heat exchangers cover not only the heat requirement of hydrolysis reaction, but also heating up water streams from 25°C to 67.52°C.

By using Aspen Energy Analyzer with its cost parameters, Fig. 4 provides the result obtained from the targeting of ΔT_{\min} by minimizing the annual capital cost, annual operating cost, and annual total cost. It appears that a trade-off between costs of capital and operating induces the minimum annual total cost at the optimum ΔT_{\min} near the pinch point. $\Delta T_{\min} = 9^\circ\text{C}$ near the pinch is roughly estimated to confirm the initial system design.

TABLE V. POSSIBLE COST FOR RAW MATERIALS AND PRODUCTS

Component	Massrate (kg/yr)	Price (\$/kg)	Annual Cost/value (\$/year)
H2	335700	3.3	1,107,810.00
O2	2664324	3.31	8,818,912.44
HCl (g)	1686.574	0.241	406.46
CuCl (aq)	9166.342	7.2	65,997.66
Cu (s)	2939.476	83.25	244,711.38

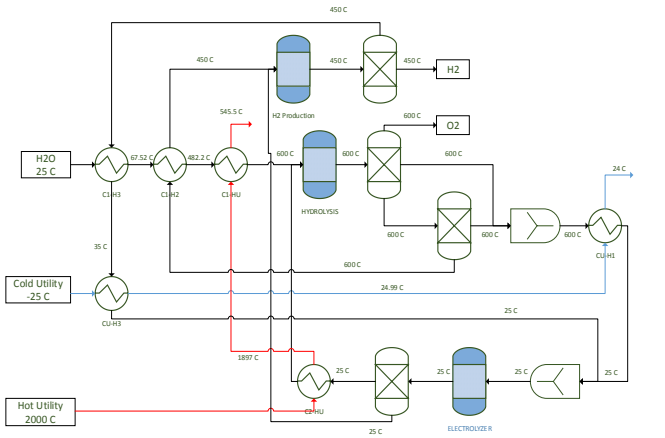

Figure 3. Heat integration of the simplistic three-step Cu-Cl thermochemical cycle

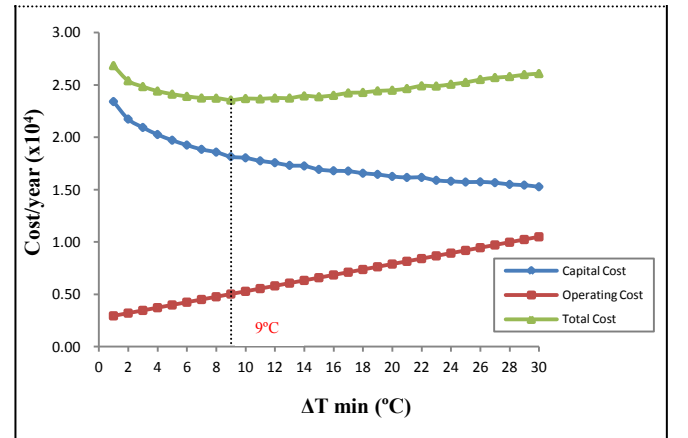

Figure 4. Targeting ΔT_{\min} by minimizing the annual costs

V. CONCLUSION

The purpose of this study was to present a new approach of hydrogen production via three-step Cu-Cl thermochemical cycle. In terms of hydrogen yield and greenhouse gases emissions, its performance is superior to any other processes due to its yield of hydrogen and oxygen only with water feed. The HEN design by using pinch point analysis were performed in order to address the system with the maximum heat recovery. The estimation of minimum annual total cost for the heat integration was carried out using Aspen Energy Analyzer with its cost parameters.

ACKNOWLEDGMENT

Thanks are due to the Ministry of Science and Technology of Taiwan, for its partially financial support of this research under grant NSC 102-2221-E-006-258.

REFERENCES

- [1] Aghahosseini S, Dincer I, Naterer G.F., "Integrated Gasification and Cu-Cl Cycle for Trigenation of Hydrogen, Steam and Electricity." *Int J Hydrogen Energy*, vol. 36, pp. 2845-54, Jan. 2011
- [2] Orhan, M.F., Dincer, I., Rosen M.A., "Efficiency Comparison of Various Design Schemes for Copper-chlorine (Cu-Cl) Hydrogen Production Processes Using Aspen Plus Software." *Energy Conversion and Management*, vol. 63, pp. 70-86, Apr. 2012
- [3] Rosen, M.A., "Advances in Hydrogen Production by Thermochemical Water Decomposition: A Review." *Energy*, vol. 35, pp. 1068-1076, July 2010.
- [4] Lewis, M.A., Ferrandon, M.S., Tatterson, D.F., Mathias, P., "Evaluation of Alternative Thermochemical Cycles - Part III Further Development of The Cu-Cl Cycle." *Int J Hydrogen Energy*, vol. 34, pp. 4136-45, May 2009.
- [5] Lewis, M.A., Masin, J.G., "The Evaluation of Alternative Thermochemical Cycles - Part II: The Down-Selection Process." *Int J Hydrogen Energy*, vol. 34, pp. 4125-35, May 2009.
- [6] Naterer, G.F., Suppiah, S., Lewis, M., Gabriel, K., Dincer, I., Rosen, M.A., et al. "Recent Canadian Advances in Nuclear - Based Hydrogen Production and The Thermochemical Cu-Cl Cycle." *Int J Hydrogen Energy*, vol. 34, pp. 2901-17, Apr. 2009.
- [7] Zamfirescu, C., Dincer I., Naterer G.F., "Thermophysical Properties of Copper Compounds in Copper-Chlorine Thermochemical Water Splitting Cycles." *Int J Hydrogen Energy*, vol. 35, pp. 4839-52, May 2010.
- [8] Zamfirescu, C., Naterer, G.F.I., Dincer, I., "Kinetics Study of The Copper/Hydrochloric Acid Reaction for Thermochemical Hydrogen Production." *Int J Hydrogen Energy*, vol. 35, pp. 4853-60, Mar. 2010.
- [9] Rosen, M.A., Naterer, G.F., Chukwu C.C., Sathankar, R., Suppiah, S., "Nuclear-Based Hydrogen Production with a Thermochemical Copper-Chlorine Cycle and Supercritical Water Reactor: Equipment Scale-up and Process Simulation." *Int J Energy Res*, vol. 36, pp. 456-65, March 2012.
- [10] Jaber, O., Naterer, G.F., Dincer, I., "Heat Recovery from Molten Cu-Cl in The Cu-Cl Cycle of Hydrogen Production." *Int J Hydrogen Energy*, vol.35, pp. 6140-51, June 2010.
- [11] Friedler, F., "Process Integration, Modelling and Optimisation for Energy Saving and Pollution Reduction." *Appl Therm Eng*, vol. 30, pp. 2270-8, Nov. 2010.
- [12] Posada, A., Manousiouthakis, V., "Heat and Power Integration of Methane Reforming Based Hydrogen Production." *Ind Eng Chem Res*, vol. 44, pp. 9113-9, Oct. 2005..
- [13] J Yoon, S.G., Lee, J., Park, S., "Heat Integration Analysis for an Industrial Ethylbenzene Plant Using Pinch Analysis." *Appl Therm Eng*, vol. 27, pp. 886-93, Apr. 2007.
- [14] Raskovic, P., Anastasovski, A., Markovska, L., Mesko, V., "Process Integration in Bioprocess Industry: Waste Heat Recovery in Yeast and Ethyl Alcohol Plant." *Energy*, vol. 35, pp. 704-17, Feb. 2010
- [15] Serban, M., Lewis, M.A., Basco, J.K., "Kinetic Study of the Hydrogen and Oxygen Production Reactions in the Copper-Chloride Thermochemical Cycle." *AIChE Spring National Meeting*, New Orleans LA, pp. 25-29, Apr. 2004.
- [16] Kemp, I.C., "Pinch Analysis, Process Integration. Pinch Analysis and Process Integration, 2nd: A User Guide on Process Integration for the Efficient Use of Energy." *Elsevier*, UK 2007.
- [17] "Aspen Energy Analyzer Tutorial Guide, Version Number: V7.1." Aspen Technology, Inc., Burlington, MA. 2009.
- [18] Corripio, A.B., Chrien, K.S., Evans, L.B., "Estimate Costs of Heat Exchangers and Storage Tanks via Correlations." *Chem. Eng.*, vol. 25, pp. 125-127, January 1982.
- [19] Mulet, A., Corripio, A.B., Evans, L.B., "Estimate Costs of Pressure Vessels via Correlations." *Chem. Eng.*, vol. 5, pp. 145-150, Oct. 1981.