

Hysteresis Compensation Using LPV Gain-scheduling

Charudatta S. Mehendale
Department of Mechanical Engineering
University of Houston
Houston, TX 77204

Karolos M. Grigoriadis*
Department of Mechanical Engineering
University of Houston
Houston, TX 77204

Abstract

The paper proposes a Linear Parameter Varying (LPV) approach to control nonlinear systems with hysteresis. An equivalent representation of the hysteretic system as a quasi-LPV system is provided. The design approach is demonstrated using a two-mass-spring system with a hysteretic spring force. The LPV controller is scheduled based on real-time measurements of the spring stiffness. The results are compared to a robust \mathcal{H}_∞ control design that considers the hysteretic stiffness variability as system uncertainty. It is shown that the LPV design provides superior performance and avoids the conservatism of the robust \mathcal{H}_∞ design. The results demonstrate that with an appropriate formulation, LPV gain-scheduling is an effective alternative to inverse compensation.

1 Introduction

Many electromechanical and structural systems exhibit hysteretic behavior due to friction, phase transition or backlash, such as, smart materials (shape memory alloys, piezoceramic and magnetostrictive materials), concrete reinforced structures, gear systems, and vibrating systems with umbilicals. Uncompensated hysteresis causes a number of undesirable effects, including poor performance, steady-state errors, limit cycle behavior and loss of stability. In high performance systems, such as, microgravity isolation systems, machining of precision parts, and lithography of microelectronic devices, hysteretic effects can result in severe degradation of quality and performance.

Current control analysis and design methods to address hysteretic effects are limited. The most widely used approach for the compensation of hysteresis is inverse compensation. This consists of formulating a mathematical model of the hysteresis, finding its (exact or approximate) inverse, and then using the inverse model to cancel the hysteretic effects. This approach has been widely employed in cases where actuators or sensors dis-

play hysteretic behavior by including these inverse models in the controller dynamics [1]. However, this inversion approach often suffers from poor knowledge of the hysteresis model and uncertainty and time variability of the hysteresis loop, resulting in residual errors and often instability. In fact, an inverse cancellation approach is not feasible if the hysteresis appears in a way so that it can not be cancelled by including the inverse model in the controller. Further, inverse models may be hard to compute or complex, and running an inverse model in real time may be too cumbersome. In this paper, we propose a novel alternative to inverse compensation for hysteresis, using LPV gain-scheduling methods.

It is well known that performance requirements and robustness specifications are conflicting design goals. Hence, in general, it is difficult to obtain good performance over a wide range of parameter variations. This observation led to nonlinear control design methods, now collectively known as gain-scheduling [2]. Gain-scheduling can be described as a divide and conquer approach, where the nonlinear control problem is decomposed into a number of linear sub-problems. Next, the wealth of knowledge of linear control design theory can be used to accommodate the linear sub-problems. In the last step, the nonlinear gain-scheduled controller is obtained by *interpolating* within the set of designed linear controllers, according to a predefined *scheduling* rule that tries to mimic the nonlinear nature of the plant.

In the present work we develop a linear parameter-varying (LPV) gain-scheduling approach to address the control problem for systems with hysteresis nonlinearity. The scheduling parameter is chosen to be the *small-signal linear gain* of the hysteresis nonlinearity. Using such a gain-scheduled controller, the inherent conflict between robustness and performance of a single robust controller is avoided, leading to improved overall performance. The proposed method is demonstrated on a two-mass-spring problem, which was posed within a benchmark collection for robust control techniques [3]. We assume that the displacement-spring force characteristic has a hysteretic nature and we compare a robust \mathcal{H}_∞ control and a LPV gain-scheduled control design for this system. The \mathcal{H}_∞ control design is used for comparison as an inverse compensation scheme is not feasible in this

*Tel: 713-743-4387; E-mail: karolos@uh.edu

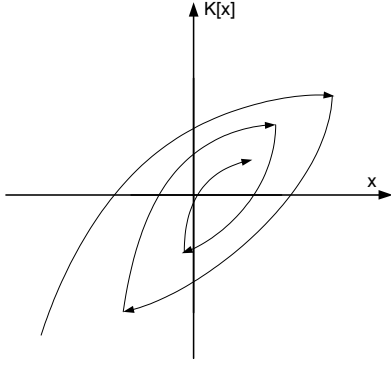

Figure 1: I/O graph of a general hysteresis operator

case. It is shown that the proposed LPV gain-scheduled controlled provides improved performance compared to the single robust \mathcal{H}_∞ controller.

The paper is organized as follows: Section 2 details the problem formulation. The two-mass-spring system with a hysteretic spring is introduced to demonstrate this approach. A critical part is the proposed novel representation of the nonlinear hysteretic system as a quasi-LPV system, without any conservatism. This leads to a LPV formulation of the hysteresis control problem. Section 3 presents the design of a robust \mathcal{H}_∞ controller and a LPV gain-scheduled controller for the two-mass-spring example which achieve given control objectives. Section 4 compares the two different design approaches using frequency domain and nonlinear time-domain simulations. Section 5 concludes the paper.

2 LPV Control of Hysteretic Systems

Consider a general nonlinear plant

$$\dot{x} = f(x, u), y = h(x, u) \quad (1)$$

where x denotes the state vector, u is the control input, and y is the measured output available for feedback. Assume that the nonlinear functions f and/or h in (1) contain a hysteretic nonlinearity K . A typical graph of the input-output characteristics of a general hysteretic operator is shown in Figure 1. We make the following important observations regarding systems with general hysteretic nonlinearities :

1. A general hysteretic operator K maps piecewise monotonic inputs to piecewise monotonic outputs. The function $K[x]$ is *not* continuously differentiable, but only piecewise continuously differentiable.
2. Future values of the output of the hysteretic trans-

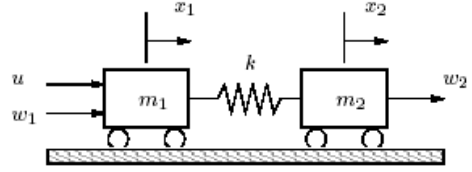

Figure 2: Two-mass-spring system

ducer depend not only on the current output value and the subsequent input variation, but also on the past history of the input extrema. Hence, at any reachable point in the input-output graph there may be an infinite number of possible directions in which the output can evolve.

3. Suppose that the inputs and the outputs of the hysteretic operator are the same at a particular instant of time t' for two different input histories till the time instant t' . However, the output at any subsequent instant, will not in general be the same, even for the same subsequent input variations.

Hence, hysteresis is a non-differentiable nonlinearity which is multi-valued and has non-local memory. Based on the above observations, we will see that in general, it is not possible to apply linearization gain-scheduling to hysteretic systems. Clearly, for the hysteretic nonlinear system (1) the functions f and/or h are only piecewise continuously differentiable and Jacobian linearization can not be carried out.

In this paper, we propose a new formulation of representing systems with hysteretic nonlinearities in a quasi-LPV form [2]. We see that a nonlinear system (1) can be written in an equivalent form, even when f and h are only piecewise continuously differentiable. The proof of this result is not provided here for the general case, but it is illustrated with a two-mass-spring system control problem that includes a nonlinear hysteretic spring.

2.1 Two-mass-spring system with a hysteretic spring

We consider the two-mass-spring system shown in Figure 2. Here m_1 and m_2 are the two masses, k represents the hysteretic spring, w_1 and w_2 denote the disturbances acting on the two masses, and u is the control force acting on m_1 . The hysteretic spring force, denoted by $K[\cdot]$, is a function of the relative displacement $x_2 - x_1$, where x_1 and x_2 denote the positions of body 1 and body 2, respectively. The position of the second body, x_2 , is the measured quantity. The differential equations of motion of the two bodies can be written as

$$m_1 \ddot{x}_1 = u + w_1 + K[x_2 - x_1], m_2 \ddot{x}_2 = w_2 - K[x_2 - x_1]. \quad (2)$$

The presence of the spring hysteretic force make this a challenging control design problem. We propose a LPV gain-scheduling based method for hysteresis compensation. The scheduling parameter is chosen to be the *small-signal linear gain* of the hysteresis nonlinearity. For the two-mass-spring system, this parameter is the ‘local’ stiffness of the spring, or the slope of the tangent to the displacement-force curve for the hysteretic spring, at the point of operation. The following section shows how to represent the above system as a quasi-LPV system.

2.2 Representation as an equivalent linear system

The nonlinear system in (2) can be written in state space form by defining the state variables $z_1 = x_2 - x_1$ (relative displacement), $z_2 = x_2$, $z_3 = \dot{z}_1$ and $z_4 = \dot{z}_2$, that is,

$$\begin{aligned}\dot{z}_1 &= z_3, \\ \dot{z}_2 &= z_4, \\ \dot{z}_3 &= -\left(\frac{1}{m_1} + \frac{1}{m_2}\right)K[z_1] + \frac{1}{m_2}w_2 - \frac{1}{m_1}(u + w_1), \\ \dot{z}_4 &= \frac{-1}{m_2}K[z_1] + \frac{1}{m_2}w_2.\end{aligned}\quad (3)$$

Proposition 1 *For the scalar hysteresis operator $K[x]$, let $\kappa(x) = \frac{dK}{dx}$ be the derivative defined at all points where K is differentiable. If $\kappa(x)$ is bounded, and the set of all points where K is not differentiable has Lebesgue measure zero, then*

$$K[x_1] - K[x_0] = \int_{x_0}^{x_1} \kappa(y)dy = \int_{t_0}^{t_1} \kappa(y(t))\dot{y}(t)dt. \quad (4)$$

Proof. Follows from theory of Lebesgue integration. ■

Using the above proposition, letting $K[x] = \int_{-\infty}^x \kappa(\tau)\dot{z}_1(\tau)d\tau$, and by redefining the state variables, we can re-write the state equations (3) after careful re-organization as

$$\dot{z}_1 = q_1, \quad (5)$$

$$\dot{z}_2 = q_2, \quad (6)$$

$$\dot{q}_1 = q_3 + \frac{1}{m_2}w_2 - \frac{1}{m_1}w_1, \quad (7)$$

$$\dot{q}_2 = q_4 + \frac{1}{m_2}w_2, \quad (8)$$

$$\dot{q}_3 = -\left(\frac{1}{m_1} + \frac{1}{m_2}\right)\kappa q_1 - \frac{1}{m_1}\dot{u}, \quad (9)$$

$$\dot{q}_4 = -\frac{1}{m_2}\kappa q_1. \quad (10)$$

The output equation is

$$y_1 = z_2 + v \quad (11)$$

where v denotes the sensor noise. The displacement of body 2 is the measured output available for feedback. The above state equations (5)-(11) have been obtained without any approximations. Hence, no conservatism is inherent in this approach, but the order of the system (5)-(11) has been increased by two. The plant model (5)-(11) has a form that is amenable to linear robust control design or LPV gain-scheduling. The time-varying plant (5)-(11) is represented as a quasi-LPV system scheduled on the parameter $\sigma \equiv \kappa$. The stiffness κ is assumed to be *a priori* unknown, but measurable in real-time. This model (5)-(11) will be used to demonstrate the effectiveness of the proposed LPV gain-scheduling compared to a robust \mathcal{H}_∞ control design.

2.3 Design objectives and constraints

The controlled output is the displacement of the second body, z_2 . The control objective is the step command tracking for the controlled output with the following properties:

Control objective: The displacement of the second body z_2 is to be made to track a step reference command.

Control constraint: Control effort should be limited, $|u| < 1$.

Performance objective: Settling time and overshoot are both to be minimized.

Robustness: Performance and stability with respect to parameter variations needs to be achieved.

The control design should take into account the following considerations:

Position sensor noise: The position sensors tend to be noisy at high frequency. In order to reject this noise, the position control loop must be adequately rolled off at high frequency.

Nonlinear spring hysteresis: The spring is assumed to have a hysteretic stiffness κ within the whole range of motion. This causes the stiffness to vary over the range of displacement. It is assumed that this variation lies in the interval [30, 70]. This low frequency parametric uncertainty is taken into account in the \mathcal{H}_∞ design by modeling it as an output multiplicative uncertainty. In contrast, the LPV gain-scheduled controller is scheduled on κ to take the real-time knowledge of the stiffness variability into account.

The next section carries out the \mathcal{H}_∞ robust control design and the LPV gain-scheduled controller design, in view of achieving the above objectives. In the benchmark problem under consideration, the mass of the first body is $m_1 = 1$, and the mass of the second body is $m_2 = 10$. The parameter σ must be allowed to have an

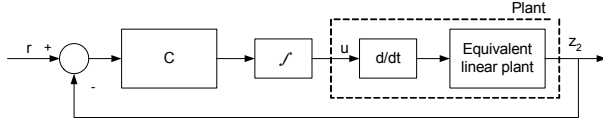

Figure 3: Design control loop

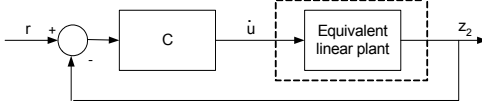

Figure 4: Reformulated design loop

infinite rate of variation to account for the jump discontinuities in κ .

3 Control design formulation and solution

It is observed that there is a derivative operator at the plant input; the control input u appears in the state equations (5)-(11) as \dot{u} . Note that, steady state performance specification requires that the controller contains a pure integral action. By explicitly partitioning the controller into a pure integral term and some additional dynamics C , the design loop with the equivalent linear plant is shown in Figure 3. Equivalently, the design loop may be reformulated as shown in Figure 4. The task is now to determine the robust \mathcal{H}_∞ controller, denoted C_∞ , or the LPV controller dynamics, C_{LPV} , which will achieve the required performance when applied to the reformulated plant (Figure 4). The controller for the original nonlinear system (2), is realized as the dynamics C_∞ or C_{LPV} followed by a pure integrator (See Figure 3). Next, the two control designs are presented.

3.1 Robust \mathcal{H}_∞ control design

The performance requirements are specified in terms of induced \mathcal{L}_2 norms, as it is standard in \mathcal{H}_∞ control theory, by appropriately weighting the signals of interest. The augmented control design interconnection is shown in Figure 5. The exogenous inputs to the augmented system are $[w_1, w_2, r, w_3, noise]^T$ and the error outputs are $[e_1, e_2, e_3]^T$. w_1 and w_2 are the disturbances affecting masses 1 and 2, respectively, and r is the reference command input that must be tracked by the output z_2 . The signals w_3 and $noise$ denote, respectively, the fictitious signal from the output multiplicative uncertainty block, and the position sensor noise signal. The error vector is composed of the signal e_1 that drives the multiplicative uncertainty block, the weighted reference tracking error

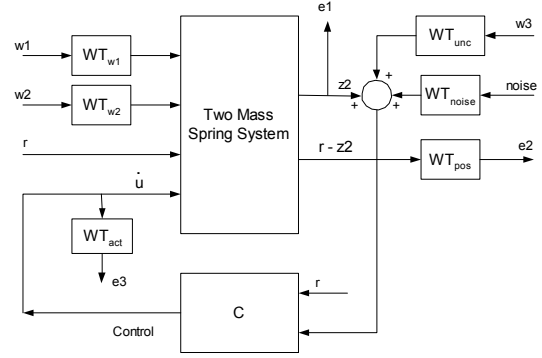

Figure 5: Augmented control design interconnection

e_2 , and the weighted control effort e_3 . The objective is to robustly stabilize the open loop system and minimize the energy-to-energy gain from the disturbance signal $[w_1, w_2, r, w_3, noise]^T$ to the error signal $[e_1, e_2, e_3]^T$.

The weighting functions are used to shape the transfer functions from the disturbance inputs to the error outputs. One of the main weighting functions is the weight on the tracking error, WT_{pos} . We choose

$$WT_{pos} = \frac{10^{-3}(s + 2\pi 10^{-1})}{s + 2\pi 10^{-5}}.$$

The weight WT_{pos} has high gain at low frequencies and rolls off at -20 dB/decade with crossover at 0.01 Hz, and levels off at around 1 Hz. Hence, the performance specification is that of reference tracking up to a frequency of 0.01 Hz and small steady state error for constant reference commands. The weights WT_{noise} for position sensor noise, and WT_{act} for the control effort are chosen to be constants. We select $WT_{noise} = 10^{-4}$ and $WT_{act} = 10^{-3}$. The uncertainty weight WT_{unc} is given by

$$WT_{unc} = \frac{0.12}{(2s + 1)^2}.$$

The uncertainty due to stiffness variations is dominant at low frequencies, and hence, the uncertainty weight WT_{unc} has larger magnitude at low frequencies and rolls off at -40 dB/decade around 0.1 Hz.

The robust \mathcal{H}_∞ controller synthesis problem is solved for the robust controller dynamics C_∞ , using efficient interior point methods [4]. Note that, the final robust \mathcal{H}_∞ controller for the nonlinear system (2), is realized by augmenting an integrator at the output of C_∞ .

3.2 LPV gain-scheduled control design

An LPV gain-scheduled control design with quadratic performance specifications is now developed (see [5] and the references therein). Recall that, a linear parameter-dependent representation has been obtained for the non-

linear system (2), by choosing the stiffness κ to be the parameter σ in the equivalent linear plant realization (5)-(11). The dynamics of the system (5)-(11) depends on the time-varying parameter $\sigma(t) = \kappa(t)$ which is assumed to be measured in real time. The rate of variation of the parameter σ is assumed to be unbounded. The objective is the same as before: design LPV control dynamics C_{LPV} so that the effect of the exogenous disturbance signal on the error output is minimized, for all possible parameter trajectories.

In the LPV design, we choose to specify the performance requirements in terms of induced \mathcal{L}_2 norms, as in the robust \mathcal{H}_∞ control approach. Hence, the control design interconnection is the same as in Figure 5, except that, there are no multiplicative uncertainty weight blocks or signals involved. This follows from the fact that, the LPV controller is not designed to be robust to stiffness variations; the stiffness is the parameter that is used to schedule the LPV controller. Hence, the LPV controller has the ability to alter its dynamics to better achieve the performance requirements. The tracking error weight WT_{pos} used in the LPV controller design is

$$WT_{pos} = \frac{10^{-3}(s + 2\pi 10^{-1})}{s + 2\pi 10^{-7}}.$$

The weight WT_{pos} has high gain at low frequencies, and rolls off at -20 dB/decade with a crossover frequency of 10^{-4} Hz. This weight is less ‘demanding’ (lower crossover frequency) than the tracking weight used in the design of the robust \mathcal{H}_∞ controller. All other weighting functions remain the same as earlier. It will be seen that the LPV controller achieves the same tracking response as the \mathcal{H}_∞ controller, with a less stringent design weight WT_{pos} . The weighted augmented system is a parameter-dependent system, and the LPV controller dynamics, C_{LPV} can be found using standard design software from the MATLAB LMI toolbox [4]. The final LPV controller for the nonlinear system (2), is realized by augmenting an integrator at the output of C_{LPV} , and is scheduled on the real-time measurements of the stiffness κ .

4 Numerical results

The proposed robust \mathcal{H}_∞ and LPV controllers are validated via frequency response analysis, and time domain simulations, using a nonlinear hysteretic spring model. The nonlinear spring model adopted for simulation in this work is the Bouc-Wen model of hysteresis [6]. If z is the relative displacement in the input to the hysteretic spring and K is the restoring force, this model can be described as

$$\dot{K} = A\dot{z} - \beta z|\dot{z}|^n - \gamma|\dot{z}||K|^{n-1}K, K(t_0) = K_0$$

where the real parameters $n = 1, A = 40, \beta = 35$, and $\gamma = 5$ control the scale and shape of the hysteresis curve. In this paper, the parameters are chosen so that the above hysteresis represents a softening spring, i.e., the stiffness κ decreases as the relative displacement is increased. The LPV controller is scheduled on the real-time measurement of the stiffness κ .

4.1 Frequency response analysis

The transfer functions from the reference command to the position of the second body z_2 , with the robust \mathcal{H}_∞ controller, at different values of stiffness in the range [30, 70] are plotted. It is seen that we achieve excellent tracking performance up to 10^{-2} Hz, as desired. Similarly, plots of the transfer functions, obtained by fixing the value of the parameter σ in (5)-(11), and closing the loop with the frozen LPV controller instance corresponding to σ , show that good tracking performance is achieved up to frequencies of 10^{-2} Hz, for the range of parameter values. Both designs appropriately reject the high frequency sensor noise. Hence, we have designed the corresponding controllers so that both the robust \mathcal{H}_∞ controller and the LPV controller have similar frequency domain characteristics. However, the \mathcal{H}_∞ controller, in addition, is robustly stable to all parameter variations, and hence, it is expected that the LPV controller will provide better performance. This can be easily seen in the nonlinear time-domain simulations of the corresponding closed-loop systems.

4.2 Time domain results

Time domain simulations were carried out for the two mass benchmark problem, with the detailed nonlinear model for the hysteretic spring, both with the robust \mathcal{H}_∞ controller, and the LPV gain-scheduled controller. The responses are compared in Figures 6 and 7. A unit step reference command is applied at $t = 0$ sec, and the displacement of the second body is measured. Figure 6 shows the tracking response with the \mathcal{H}_∞ controller (dashed) and the LPV controller (solid). It can be seen that the LPV controller has smaller rise time and smaller settling time with negligible steady state error. In contrast, the \mathcal{H}_∞ controller is sluggish and has a large settling time. Intuition based on linear control theory would suggest that the LPV controller should generate larger control signals, as its response is seen to be more aggressive of the two. The control commands generated by the two controllers during reference command tracking are compared in Figure 7. The control generated by the \mathcal{H}_∞ controller (Figure 7, dashed line) does not satisfy the design objective of $|u| < 1$. The LPV controller, however, generates a control signal (Figure 7, solid line), with peak value more than 50% smaller than that of the \mathcal{H}_∞ controller and satisfies the constraint

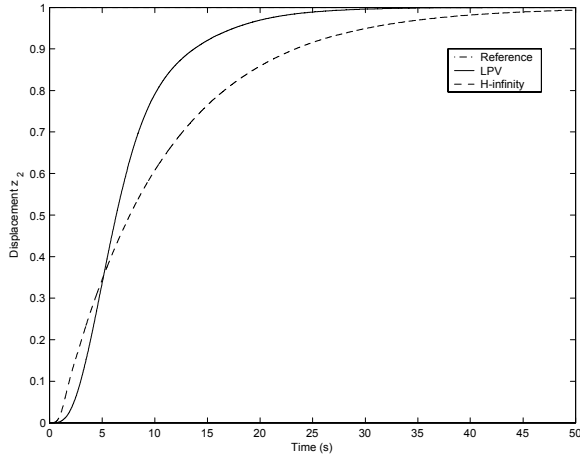

Figure 6: Comparison of tracking response

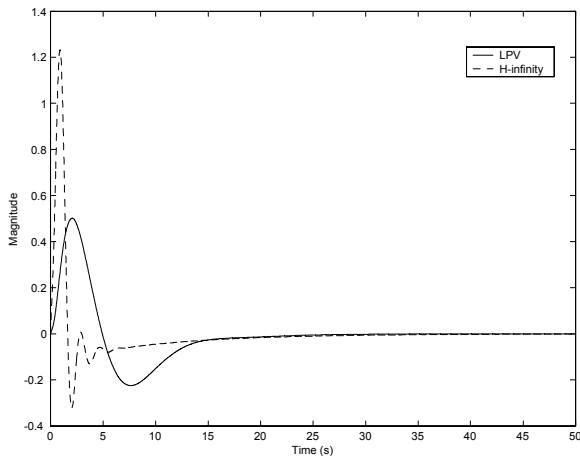

Figure 7: Comparison of control effort

$|u| < 1$. Hence, the LPV controller does a better job (faster and better tracking) with significantly lower control effort. This is as expected; the \mathcal{H}_∞ controller results in a conservative design due to the inherent conflict between performance and robustness specifications, while the LPV controller designed without the robustness constraint, achieves significantly improved performance.

5 Conclusions

In this paper, we propose a novel solution to the problem of hysteresis compensation using a LPV gain-scheduled control approach. The design is illustrated using a two-mass-spring problem that was proposed as a benchmark problem for robust control design, where the spring force is assumed to have a hysteretic behavior. A new approach has been proposed to re-formulate a non-linearizable nonlinear hysteretic system as a quasi-LPV

system without any conservatism. A robust \mathcal{H}_∞ controller, and a LPV controller scheduled on the stiffness parameter were designed for this equivalent quasi-LPV system. Nonlinear time-domain simulations are used to show that the LPV controller provides improved performance compared to the \mathcal{H}_∞ controller, with significantly less control effort. Hence, the LPV controller avoids the conservatism introduced in the robust \mathcal{H}_∞ controller, by using real-time measurements of the stiffness for the purposes of scheduling. It is assumed in this work that the input of the hysteretic nonlinearity is available for measurement, in order to estimate stiffness in real time. This introduces in our case, an additional sensor. The results demonstrate that the proposed LPV-based formulation is an effective approach to address the control of hysteretic systems. The proposed method avoids the pitfalls of inverse compensation and has vast potential in applications. Future work will focus on experimental validation of the proposed solution for compensating hysteresis in smart materials.

References

- [1] Tao, G., and Kokotovic, P., V. *Adaptive control of systems with actuator and sensor nonlinearities*. John Wiley & Sons, Inc., New York., 1996.
- [2] Rugh, W., J., and Shamma, J., S., Survey Paper: Research on gain-scheduling. *Automatica*, **36**, 1401-1425, 2000.
- [3] Wie, B., and Bernstein, D., S., Benchmark problems for robust control design. *Journal of Guidance, Control and Dynamics*, **1**, No. 5., 1057-1059, 1992.
- [4] Gahinet, P., Nemirovski, A., Laub, A., and Chilali, M., *LMI control toolbox*, The Mathworks, Inc., Natick, MA, 1995.
- [5] Apkarian, P., and Adams, R. J., Advanced Gain-Scheduling Techniques for Uncertain Systems, *IEEE Transactions on Control Systems Technology*, **6**, 21-32, 1998.
- [6] Wen, Y.-K., Method for random vibration of hysteretic systems, *Journal of Engineering Mechanics*, **102**, 249-263, 1976.