



The University of Texas at Austin
McKetta Department
of Chemical Engineering
Cockrell School of Engineering

March 2022

POWER SYSTEMS, CARBON EMISSIONS, SMART GRIDS AND PROCESS CONTROL

Thomas F. Edgar

Abell Chair Emeritus, The University of Texas at Austin

Outline

- Energy trends and policy overview
- Carbon emissions and power production trends
- Next generation power systems(smart grids)
- Building energy management/optimization
- Energy storage and process control

CO₂ Emissions

- Increased CO₂ emissions and the resulting greenhouse effect have impacted climate change and have become a global concern in recent years
- The biggest contributors of CO₂ emissions are fossil energy power systems such as pulverized coal (PC) and natural gas combined cycle (NGCC), being responsible for 41% of total

Global Carbon Emissions from Fossil Fuels, 1900-2014

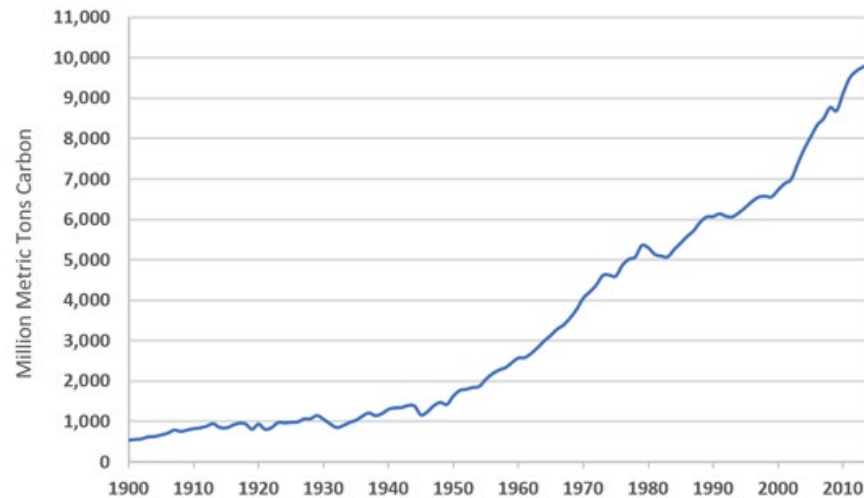

Source: US Department of Energy

Contributors of CO₂ emission

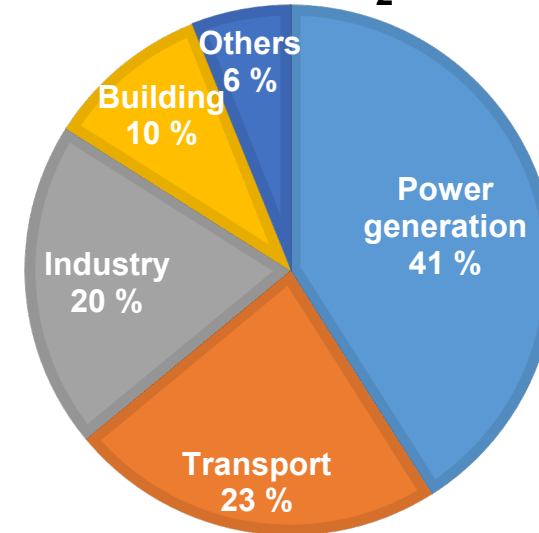

Source: International Energy Agency

The U.S. Industrial and Building Sectors

- Industrial energy usage = 35 quads; building energy usage = 40 quads (total = 100 quads)
- Building energy consumption split roughly 50:50 between commercial and residential buildings
- These two sectors account for about 70% of total U.S. GHG emissions
- By 2030, 16% growth in U.S. energy consumption, which will require additional 200 GW of electrical capacity (EIA)
- Energy efficiency goals of 25% reduction in energy use by 2030 (McKinsey and National Academies Press reports)

Policy Alternatives to Reduce Carbon Emissions

- Cap and Trade
 - Establishes firm limit on CO₂ emissions
 - Auctioning/trading of emissions permits
- Carbon Tax
 - Price predictability
 - Favored by many large companies
 - Apply to all carbon sources
- Regulated CO₂ (EPA)

Power Generation Strategies to Manage Carbon Emissions

- Use higher efficiency power cycles (e.g., combined cycle, solid oxide fuel cells)
- Fuel swapping (natural gas for coal)
- Conversion to non-fossil sources (e.g., nuclear or renewables)
- Nuclear thermal process energy
- Capture/disposal of CO₂ emissions

CO₂ Absorption/Stripping of Power Plant Flue Gas

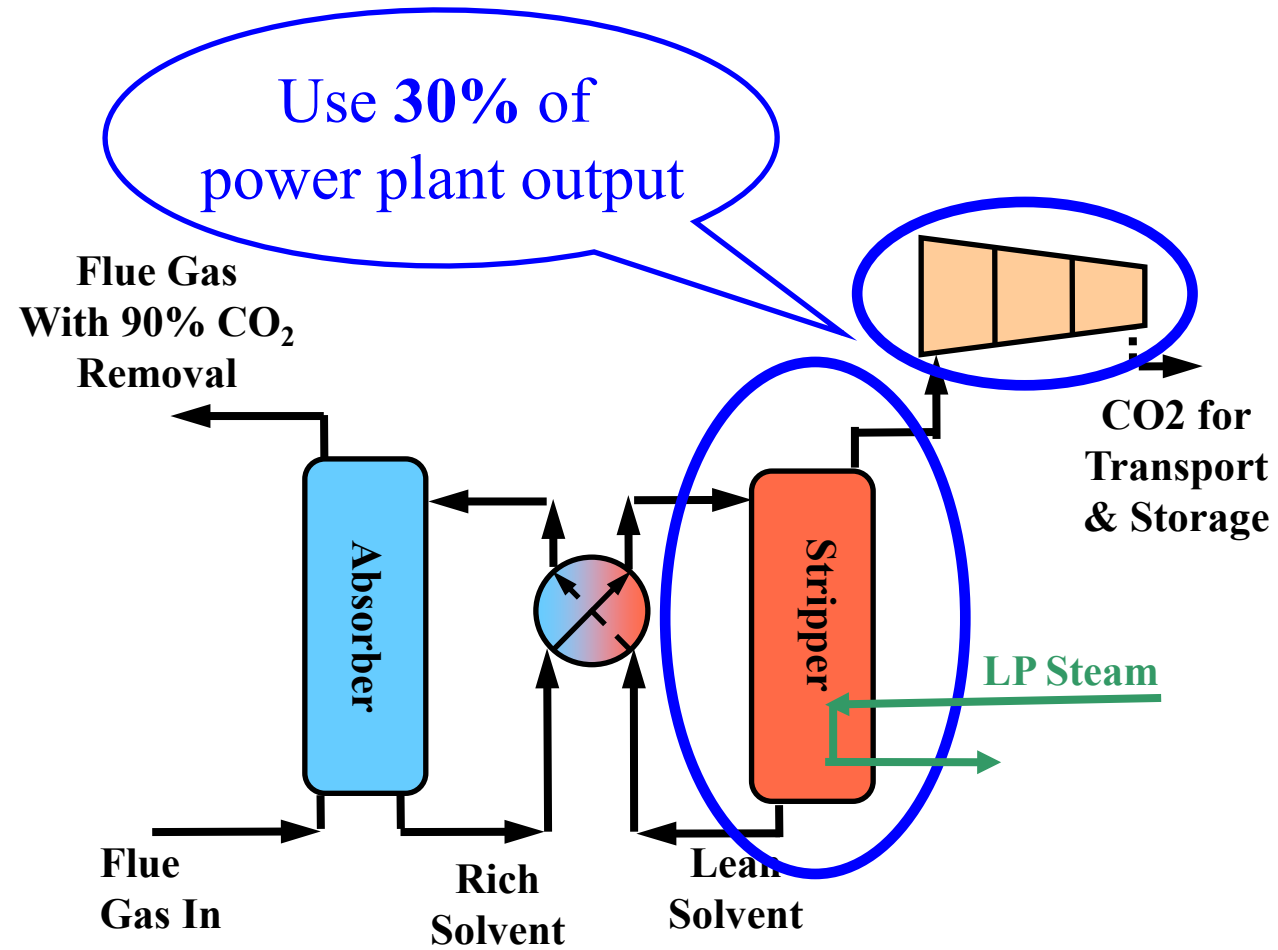

U.S. Energy Comes from Many Sources

U.S. primary energy consumption by energy source, 2018

total = 101.3 quadrillion
British thermal units (Btu)

total = 11.5 quadrillion Btu

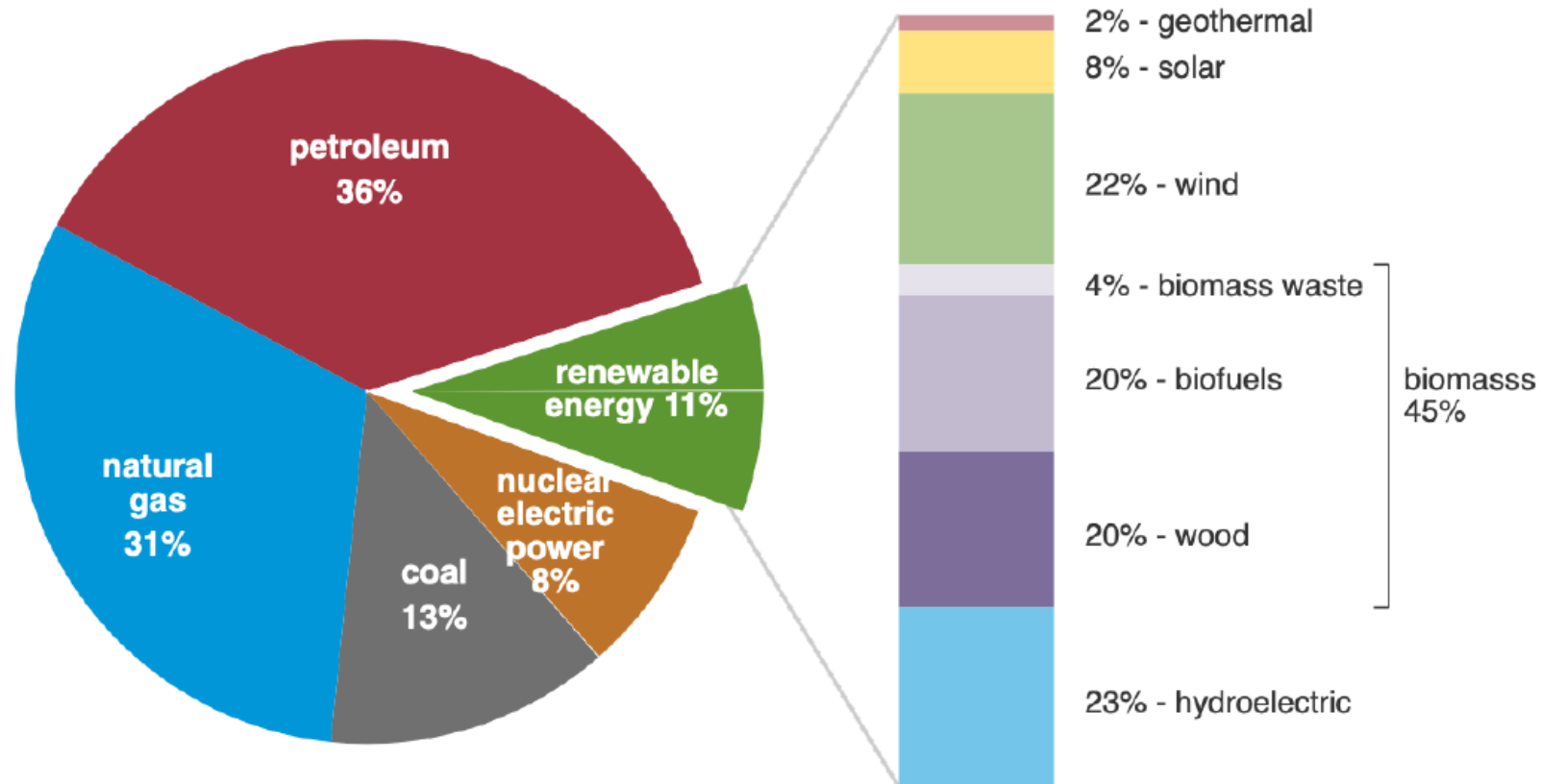

Note: Sum of components may not equal 100% because of independent rounding.

Source: U.S. Energy Information Administration, *Monthly Energy Review*, Table 1.3 and 10.1, April 2019, preliminary data

U.S. Energy Prices vs. Time

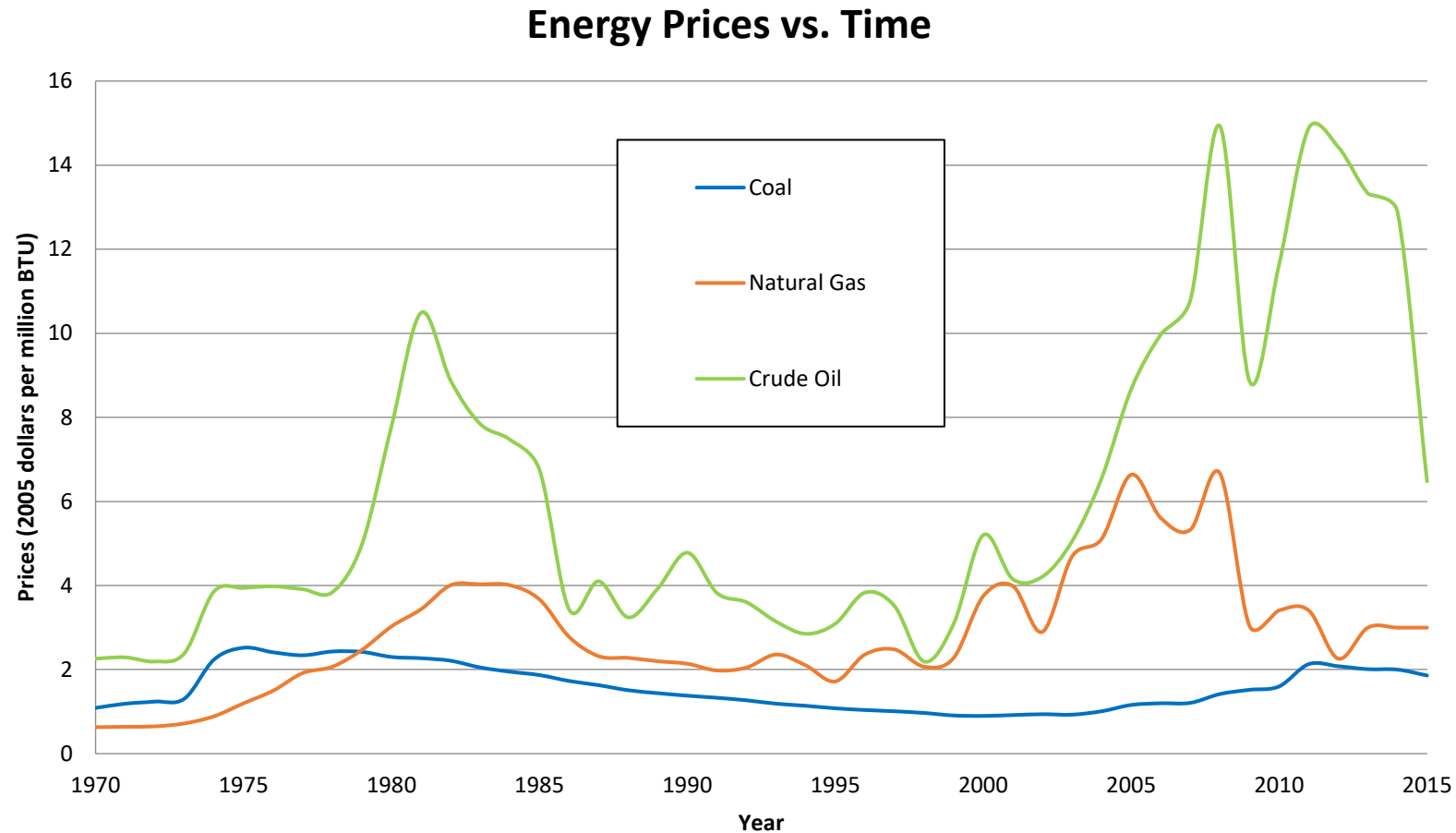

The Power Sector's Fuel Mix is Diverse

U.S. electricity generation by major energy source, 1950-2018

billion kilowatthours

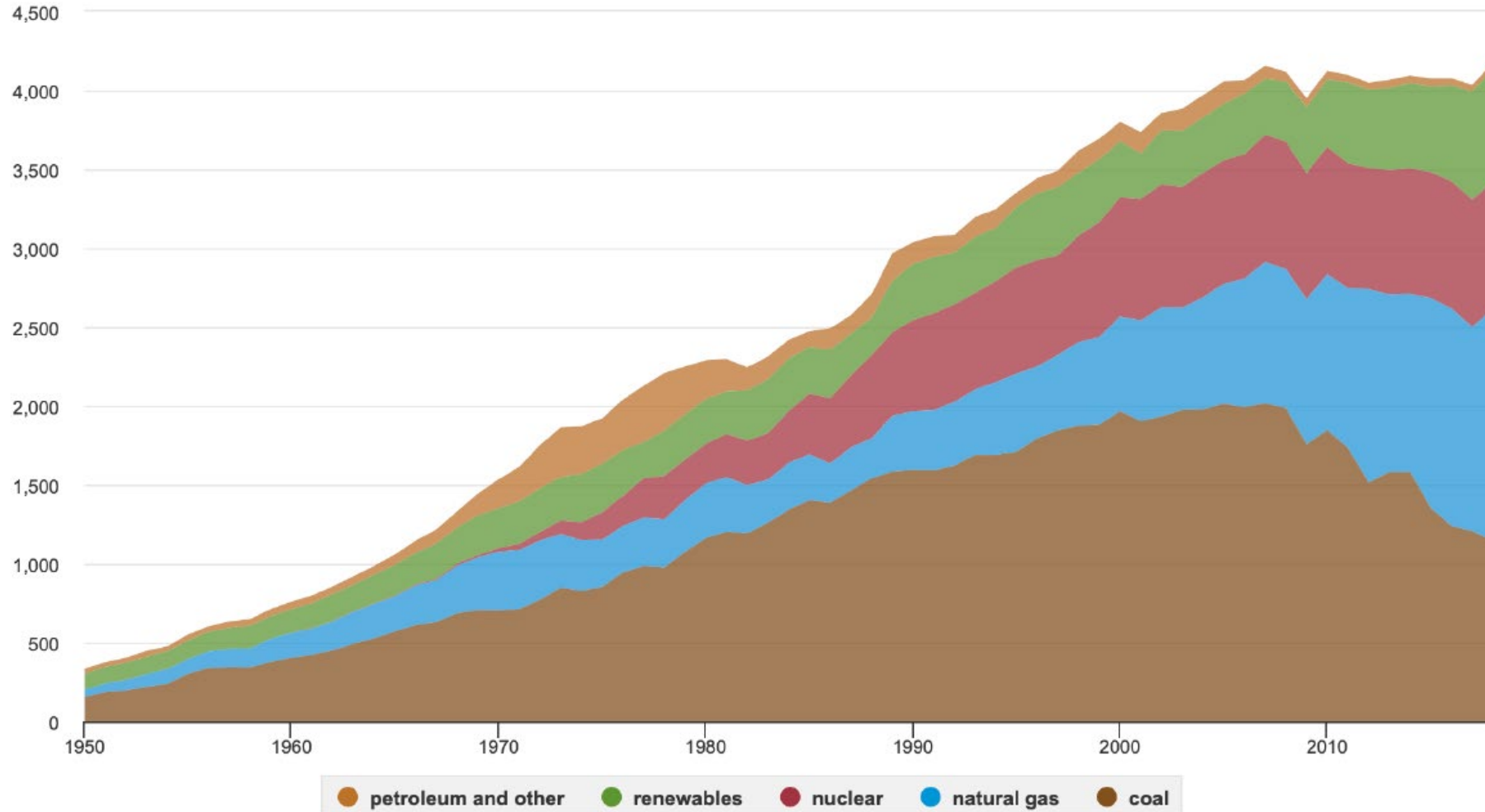

Note: Electricity generation from utility-scale facilities.
Source: U.S. Energy Information Administration, *Monthly Energy Review*, Table 7.2a, March 2019

Attitudes about Energy Have Evolved Over Time from NIMBY to BANANA



NIMBY

Not In My Back Yard

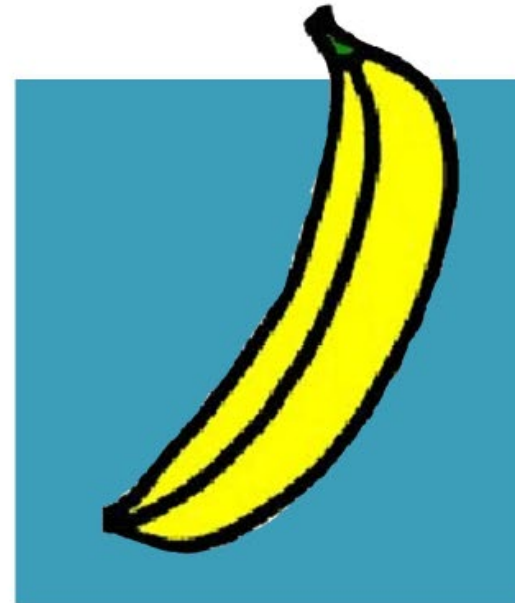
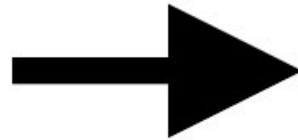

BANANA

Build Absolutely Nothing
Anywhere Near Anyone



"FIRST, THE GOOD NEWS: WE'VE SHUT DOWN THE COAL-FIRED ELECTRIC POWER PLANT IN YOUR BACKYARD.."

Type of Power Cycle Affects Thermal Efficiency

- Steam turbine driven (Rankine Cycle)
 - Uses boilers to create steam from heat (from coal, gas, Petroleum, wood, nuclear reactors)
- Gas turbines (Brayton Cycle)
 - Burns natural gas directly in turbine
- Combined Cycle (Combines Rankine + Brayton)
 - Burns natural gas directly in turbine
 - Uses waste heat in exhaust to create steam
- Combined Heat and Power (CHP)
- Integrated Gasification Combined Cycle (IGCC)

Steam-Driven Systems Have a Typical Efficiency of 30-40%

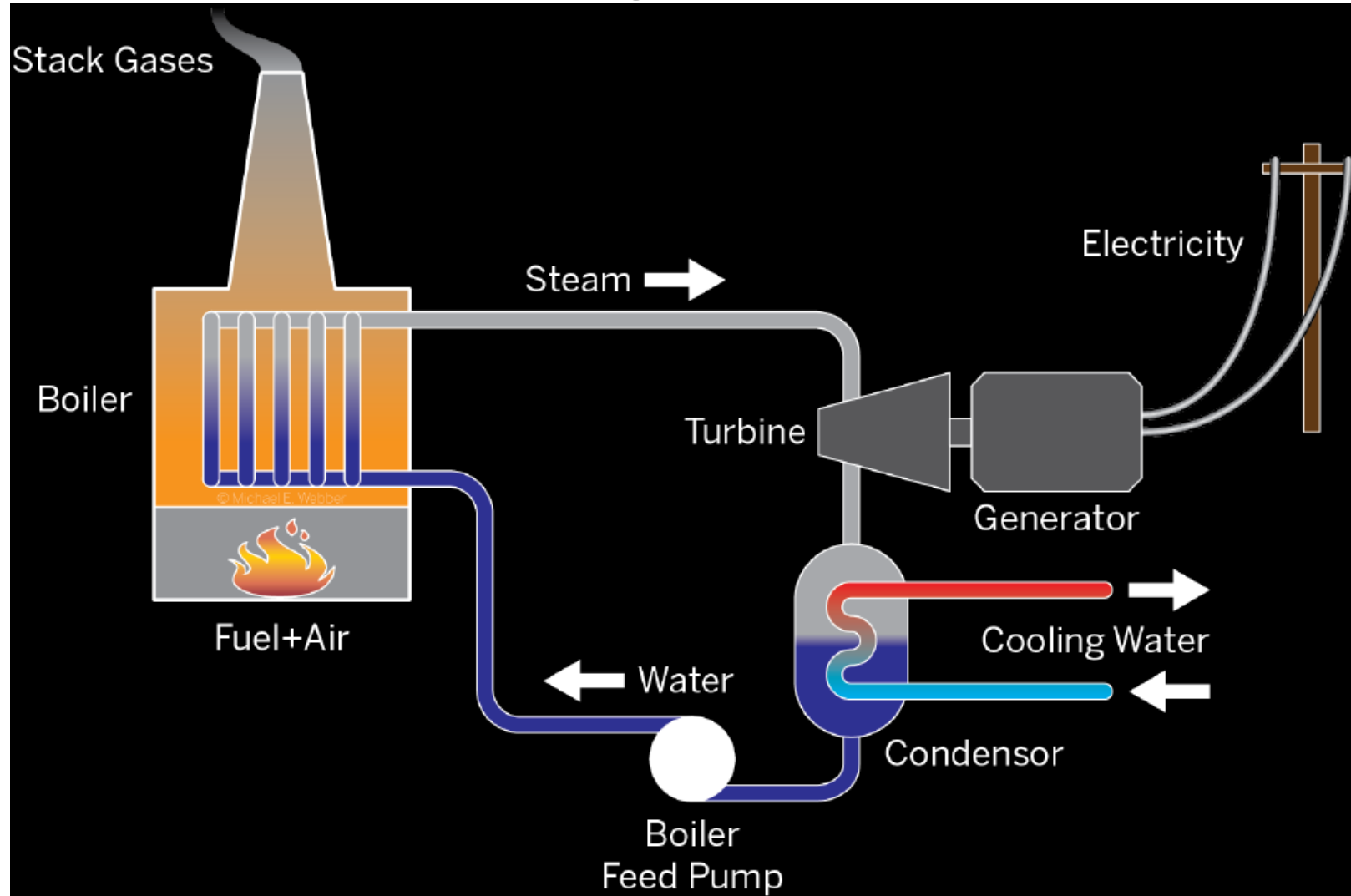

Combined Cycle Systems Have a 40-60% Efficiency

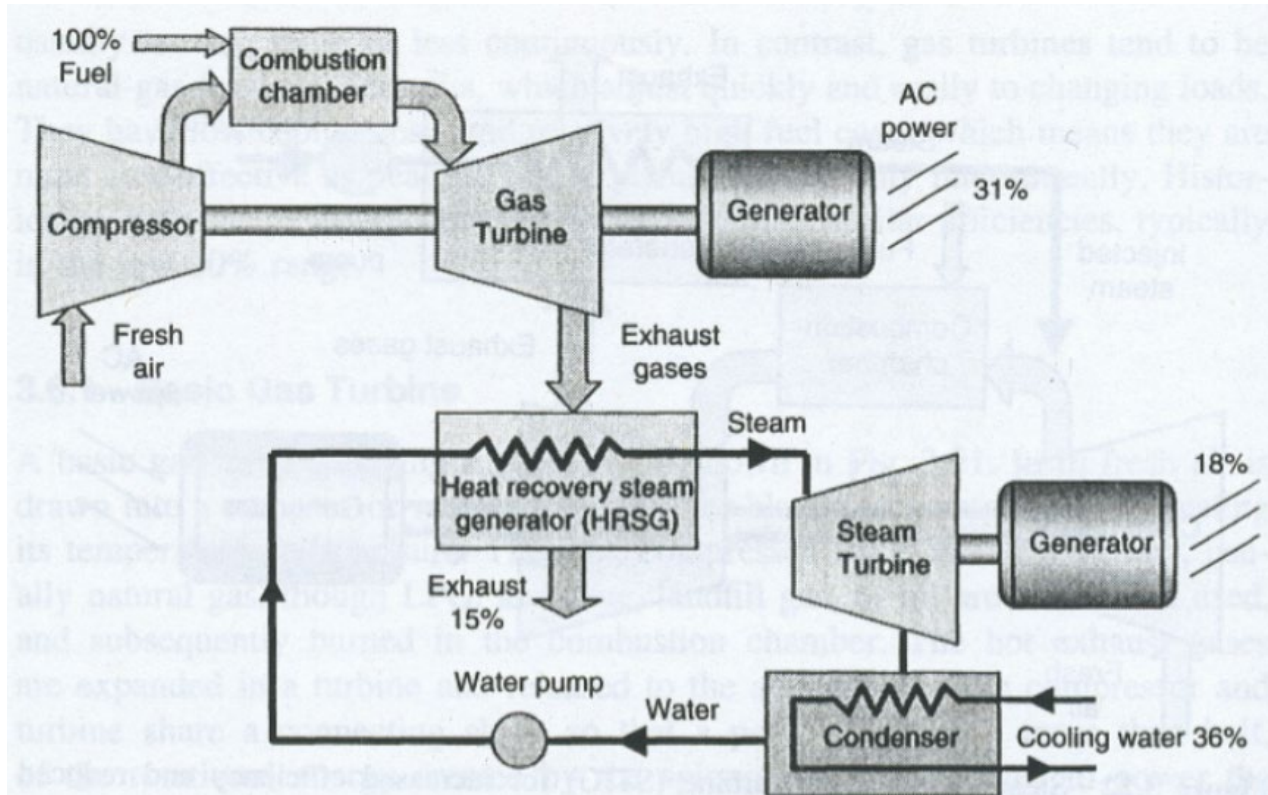
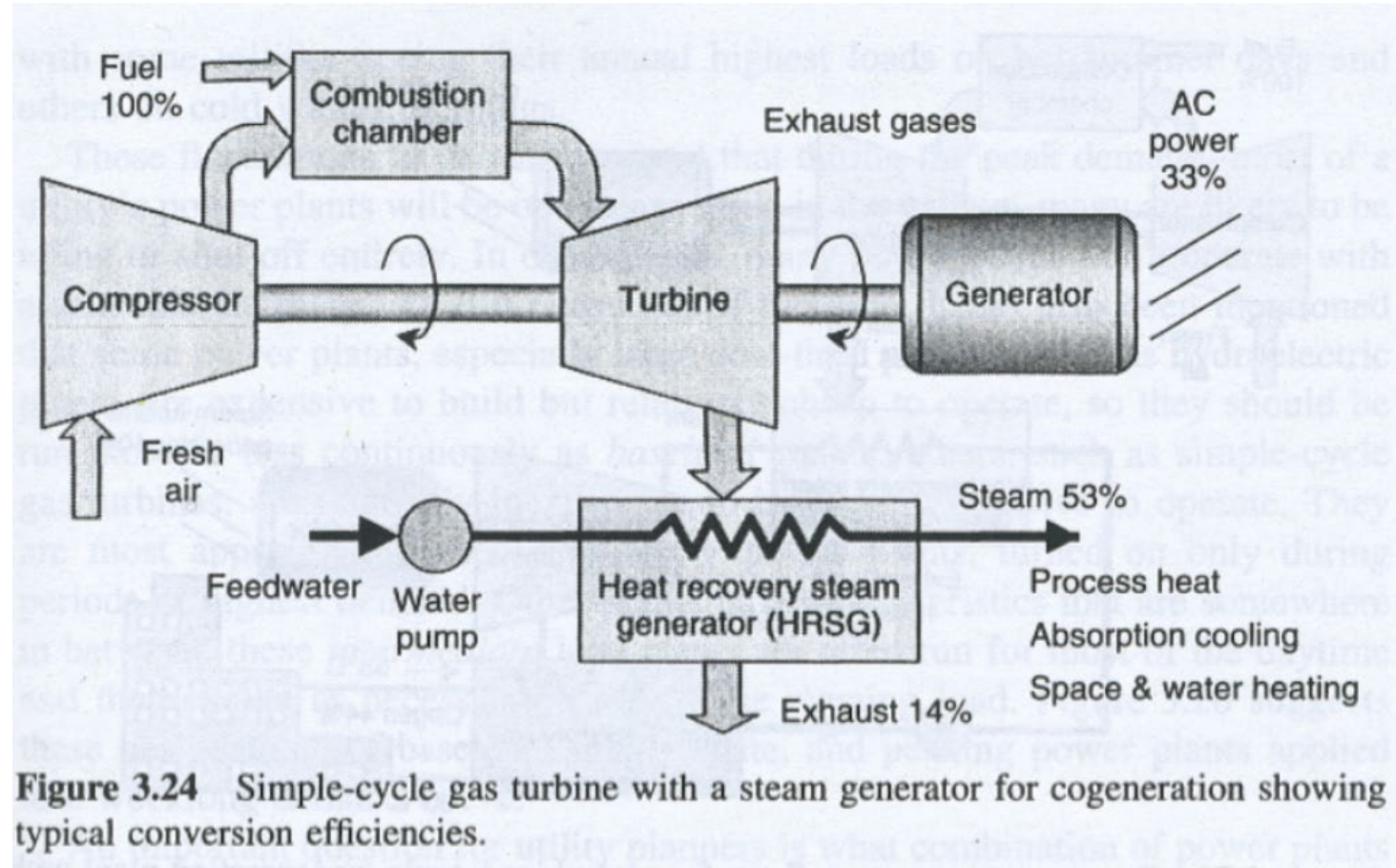

Figure 3.23 Combined-cycle power system with representative energy flows providing a total efficiency of 49%.

UT's power plant is a natural gas combined cycle (gas turbine + steam turbine)

Combined Heat and Power Systems Have a 70-80% Efficiency



Annual Distribution of Sources for Texas Electricity Production (percentage): Trends over the last three years (from ERCOT)			
	2017	2018	2019
Gas	39	42	47
Coal	32	25	20
Wind	17	19	20
Nuclear	11	11	11

Annual Distribution of Sources for Texas Electricity Production (percentage): Trends over the last three years. ERCOT

Solar Power Will Account for Nearly Half of New U.S. Electric Generating Capacity in 2022

Planned U.S. utility-scale electric generating capacity additions (2022)
gigawatts (GW)

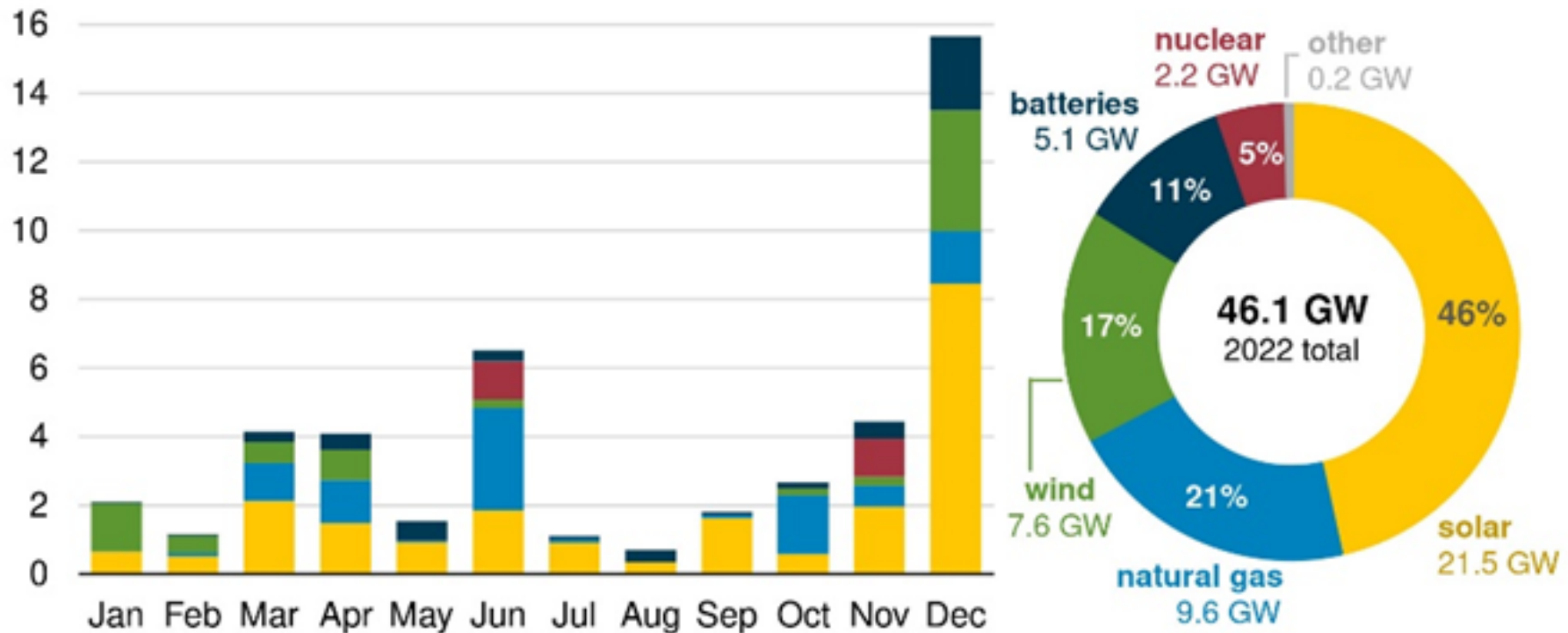

Smart Grid Has Arrived

- Next generation energy and information network
- Integrated sensing, communication, and control on both the utility and customer side
 - Real-time diagnostics, outage detection, automated relays
 - Smart meters, smart appliances, home energy management systems (HEMs), home area networks (HANs)
- New policies and markets
 - New pricing options (time of use, real-time, etc.)
 - Distributed generation
 - Distributed demand response

What is a Smart Grid?

- Delivery of electric power using two-way digital technology and automation with a goal to save energy, reduce cost, and increase reliability.
- Power will be generated and distributed optimally for a wide range of conditions either centrally or at the customer site, with variable energy pricing based on time of day and power supply/demand.
- Permits increased use of intermittent renewable power sources such as solar or wind energy and increases need for energy storage.

Smart Grid Addresses Current and Future Problems

- Current grid is aging, needs updating anyway
- Increased population, higher electricity dependence
- Manage increased intermittent generation sources (wind, solar)
- Could help manage peak demand and overall consumption
 - Avoid new plant construction
 - Use grid resources more effectively

Today's Grid

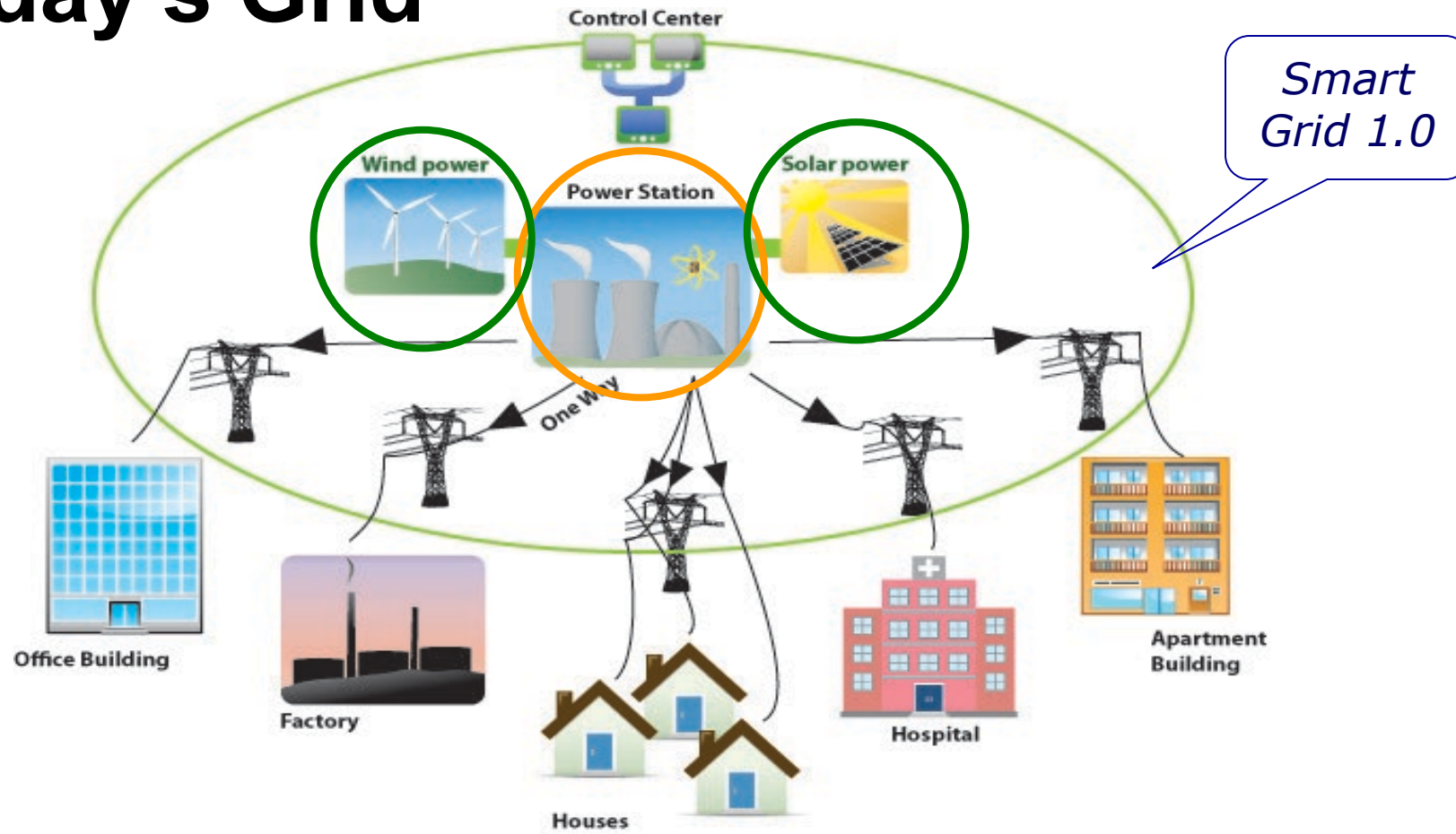

Tomorrow's Grid

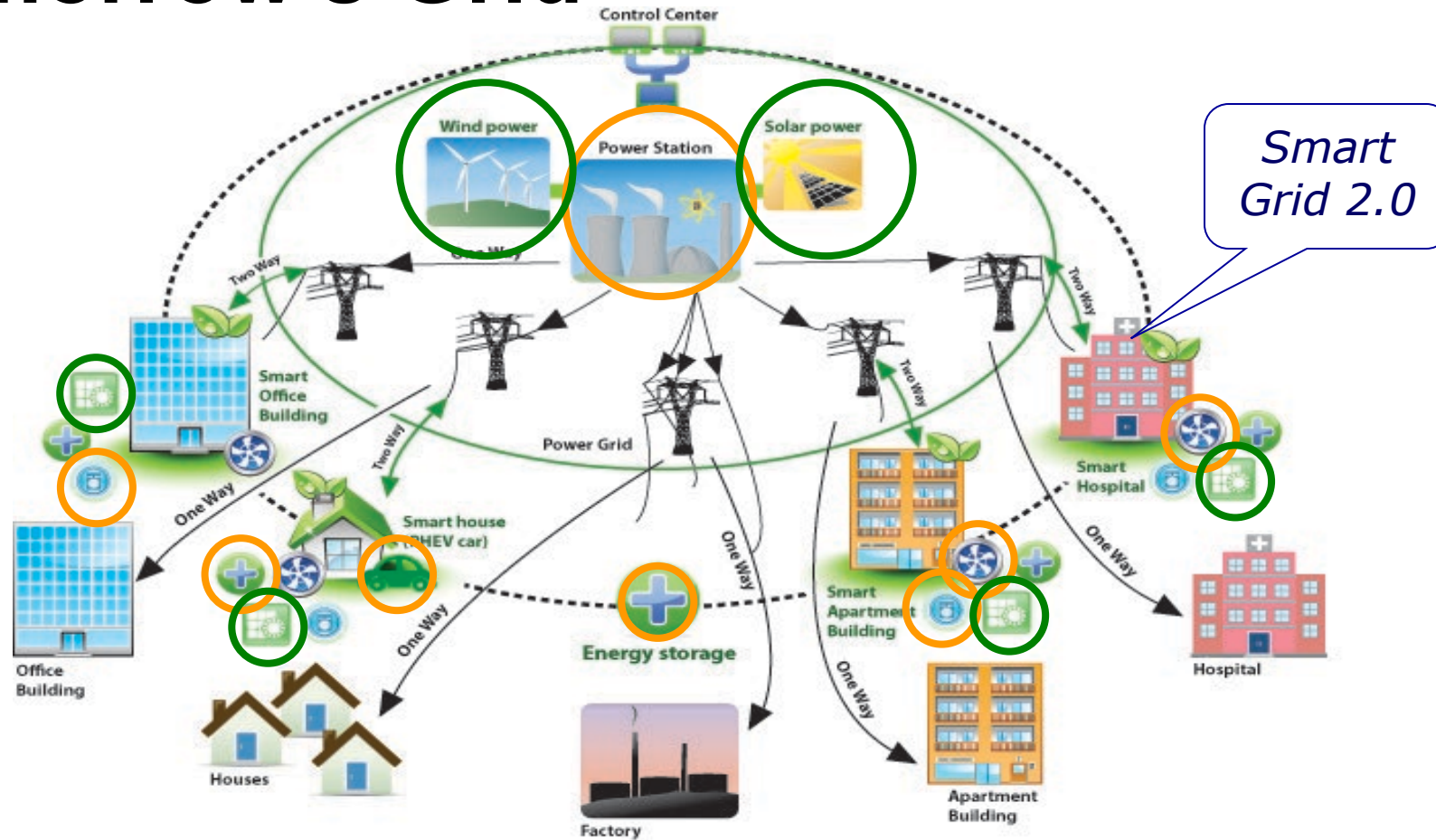
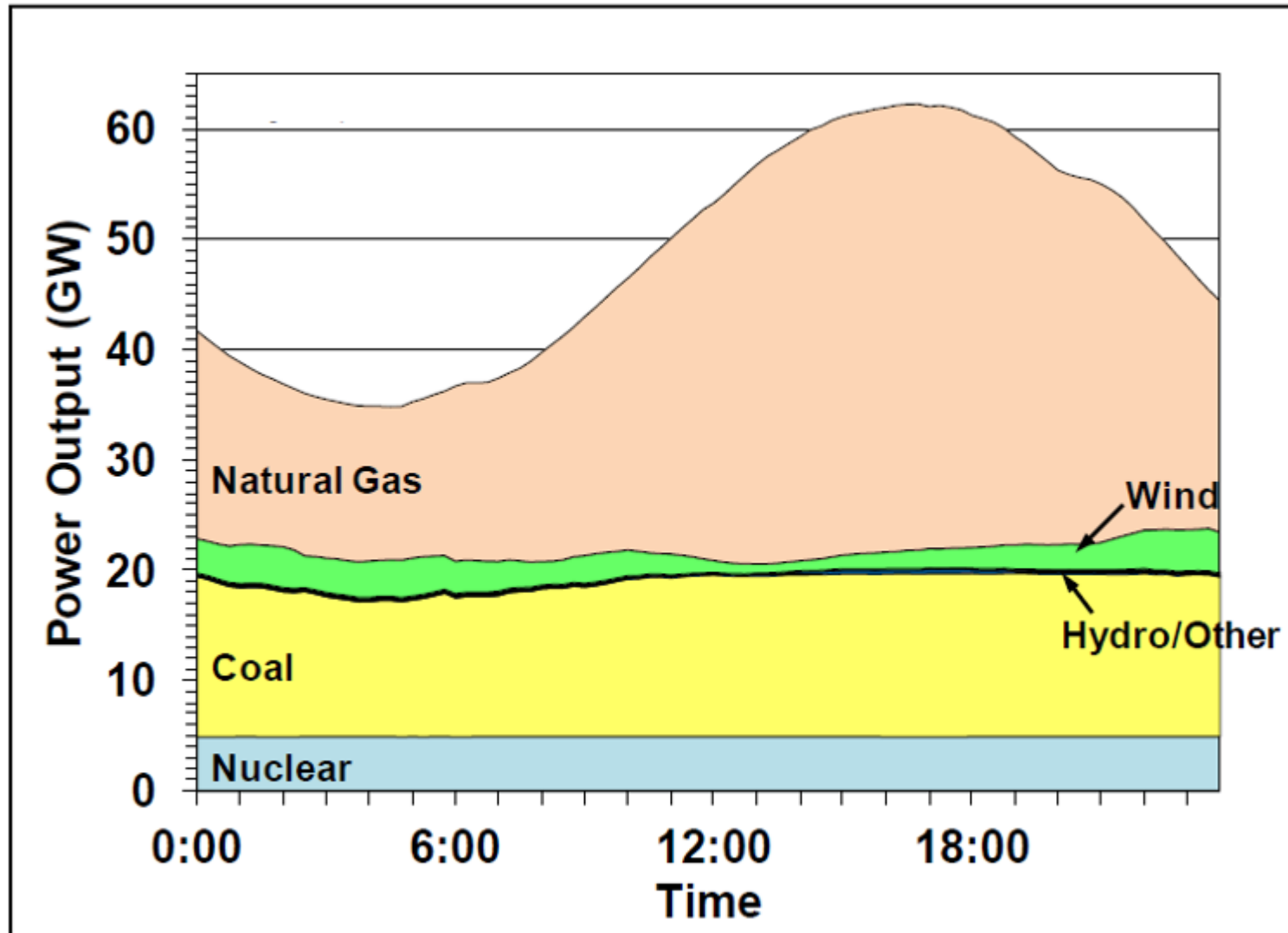
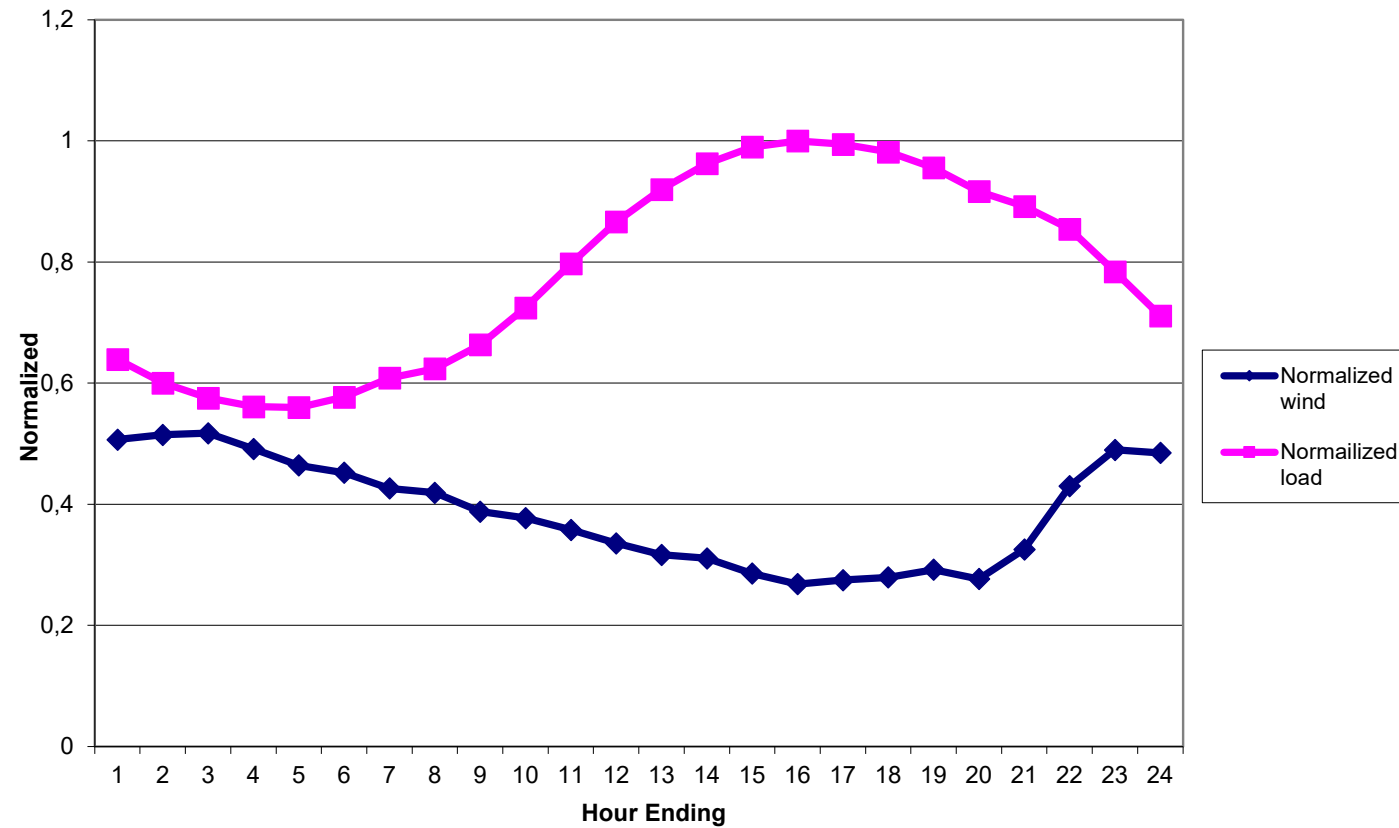

Figure 3: A typical summer day in the Texas (ERCOT) grid shows how demand varies throughout the day, over a 24-hour period (midnight to midnight)



Wind and Texas daily load



Source: Dispatchable Hybrid Wind/Solar Power Plant, Mark Kapner, P.E

Three Types of Utility Pricing

- Time-of-use (TOU) – fixed pricing for set periods of time, such as peak period, off peak, and shoulder
- Critical peak pricing (CPP) – TOU amended to include especially high rates during peak hours on a small number of critical days; alternatively, peak time rebates (PTR) give customers rebates for reducing peak usage on critical days
- Real time pricing (RTP) – retail energy price tied to the wholesale rate, varying throughout the day

Reducing Carbon Emissions from the Grid

- Decrease usage of fossil fuels (coal, natural gas)
- Increase use of renewables (wind, solar)
- Dynamic nature (intermittency) of wind and solar causes problems in balancing the grid
- However, grid demand is already dynamic in a 24 hour cycle
- Building energy management can maximize efficiency
- Need storage to balance electricity supply and demand.

Building Precooling to Save Energy

- Recent studies by NREL and LBNL indicate U.S. energy consumption could be reduced by one-third by summer precooling and central control of buildings(also reduces peak demand) as well as using heat pumps for water heaters(Langevin et al., *Joule*, July 7, 2021)
- This would halve number of new power plants needed over next 25 years
- Coordination with smart grid is important
- Use of building energy models allows optimization and control of energy use

The Peak Energy Problem

- Peak demand → high cost

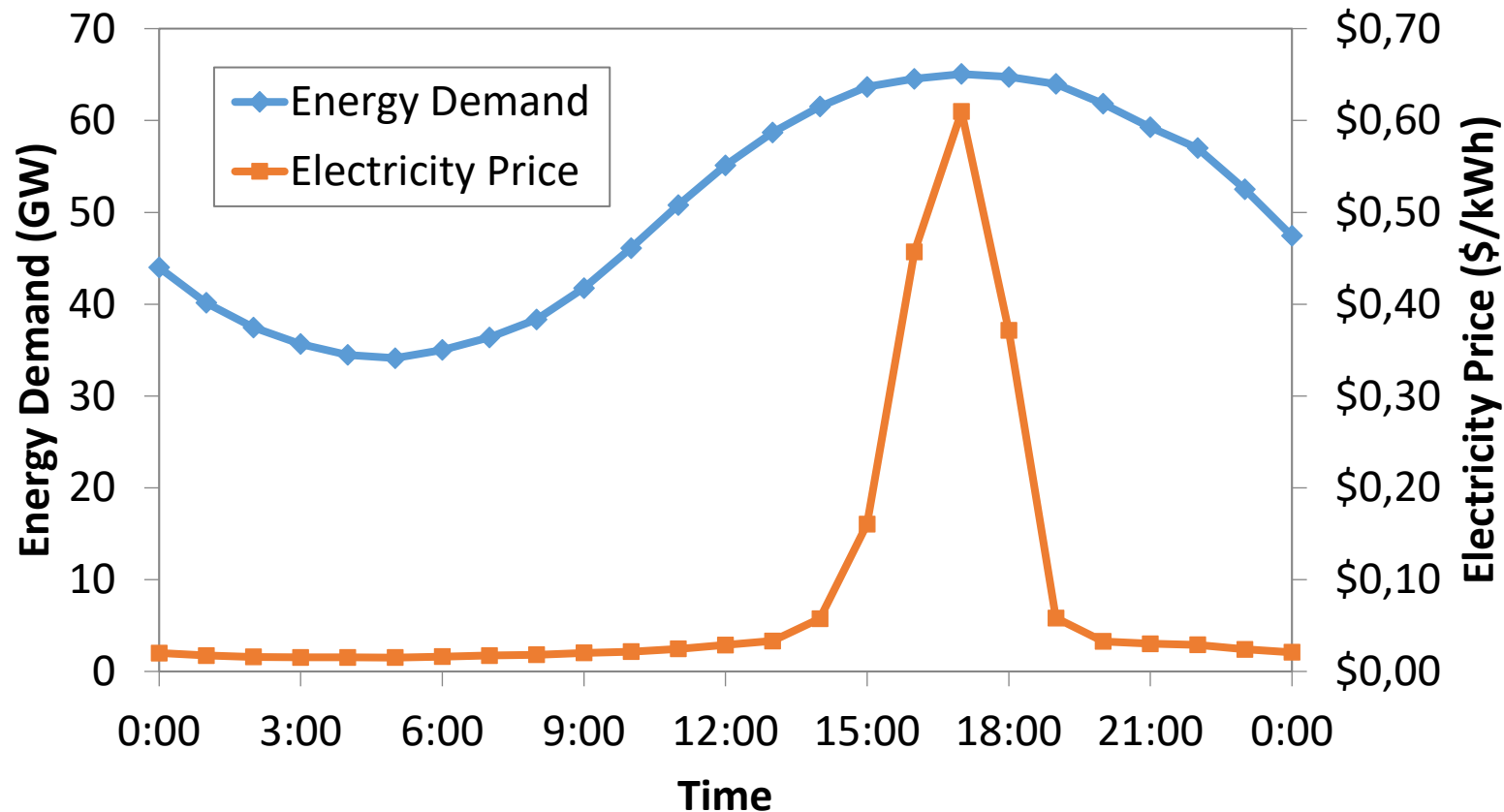

ERCOT demand and day ahead settlement point prices for June 25, 2012 from www.ercot.com

Motivation for Model Predictive Control

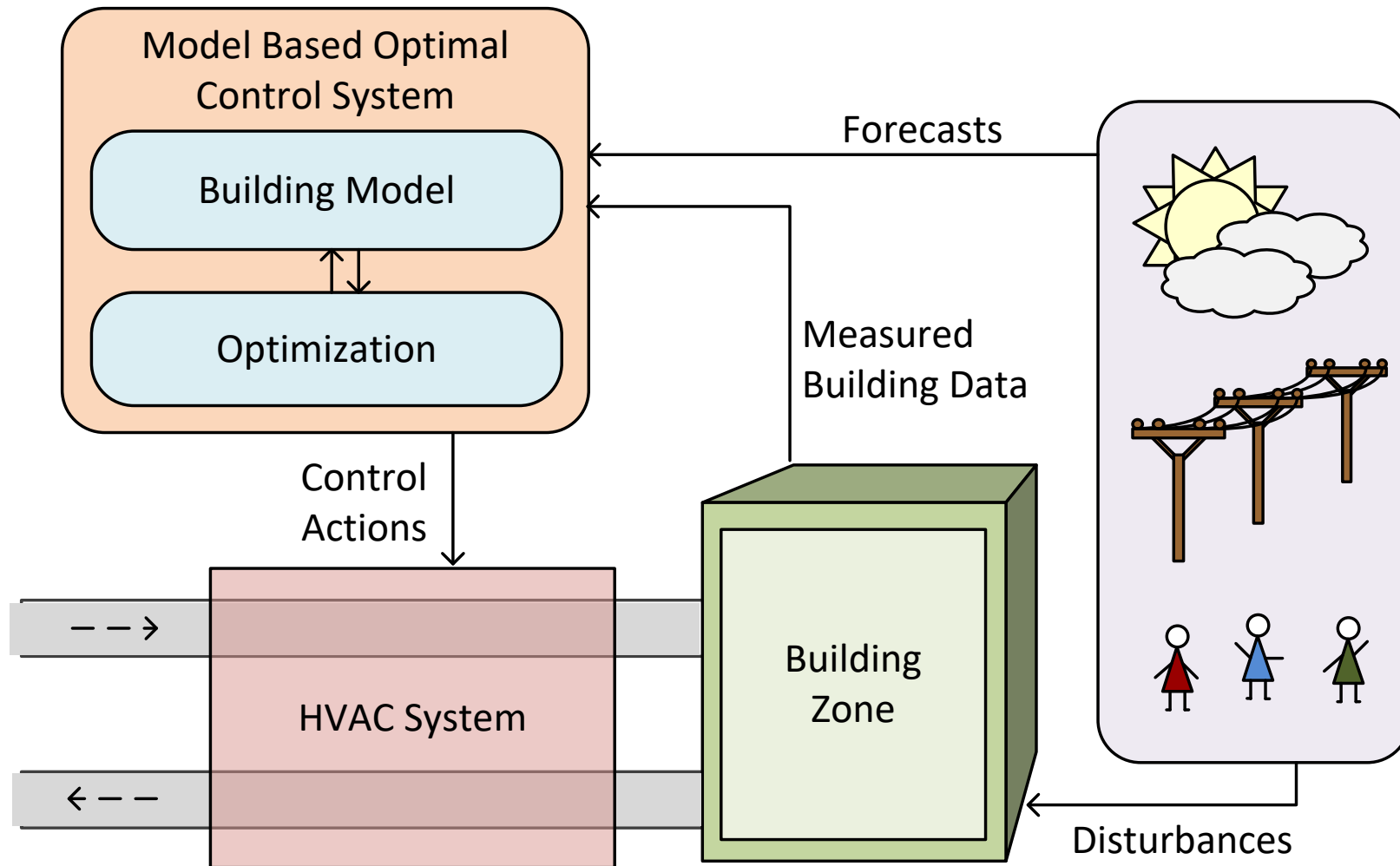

Requires “optimization-friendly” models

Building Modeling Approaches

- Inputs: weather, occupant behavior, ...
- Outputs: indoor air temp, energy use, ...

■ Linear vs. Nonlinear

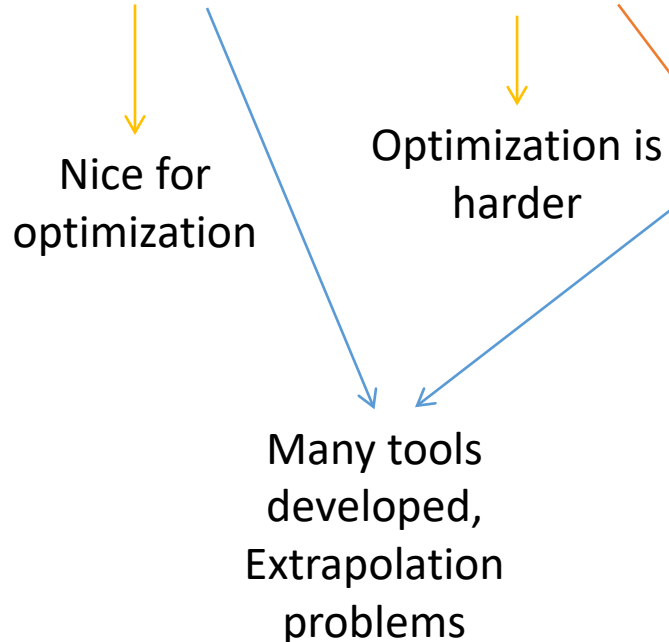

■ Data vs. First Principles

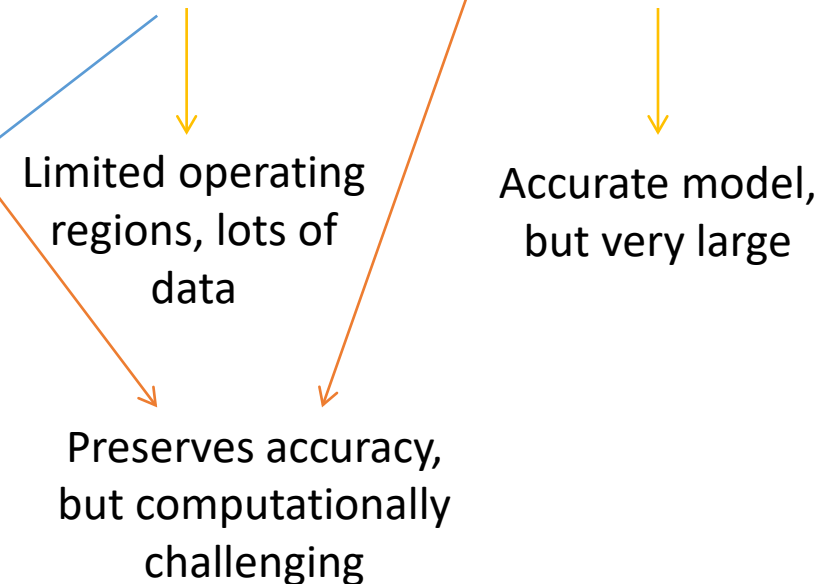

Reduced-order Model

- Variation in relative humidity not pronounced
- 3 time steps
- Linear in the thermostat set point (T)

$$y(k) = ay(k-1) + \sum_{i=0}^2 \left[b_i DBT(k-i) + c_i T(k-i) \right] \\ + d \left[DBT(k) \right]^2 + f DBT(k) \cdot T(k) + h_k$$

y = Energy Consumption

DBT = Dry Bulb Temperature

T = Thermostat Set Point

MPC Formulation

$$Cost = \min \left(\sum_{k=1}^N r_k y(k) \right)$$

s.t. $y(k) = \text{Reduced Order Model}$

$$T_{lb,k} \leq T \leq T_{ub,k}$$

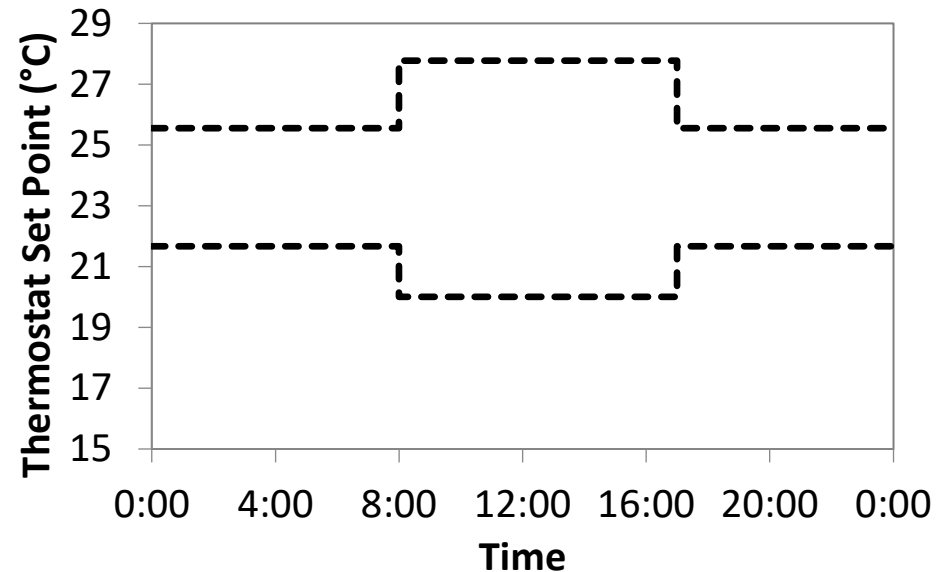

Results (Hot Summer Day)

	Base Case	Optimal Case
Total Usage	19.7 kWh	22.7 kWh
Total Cost	\$5.27	\$1.65
Peak Usage	5.7 kWh	1.4 kWh

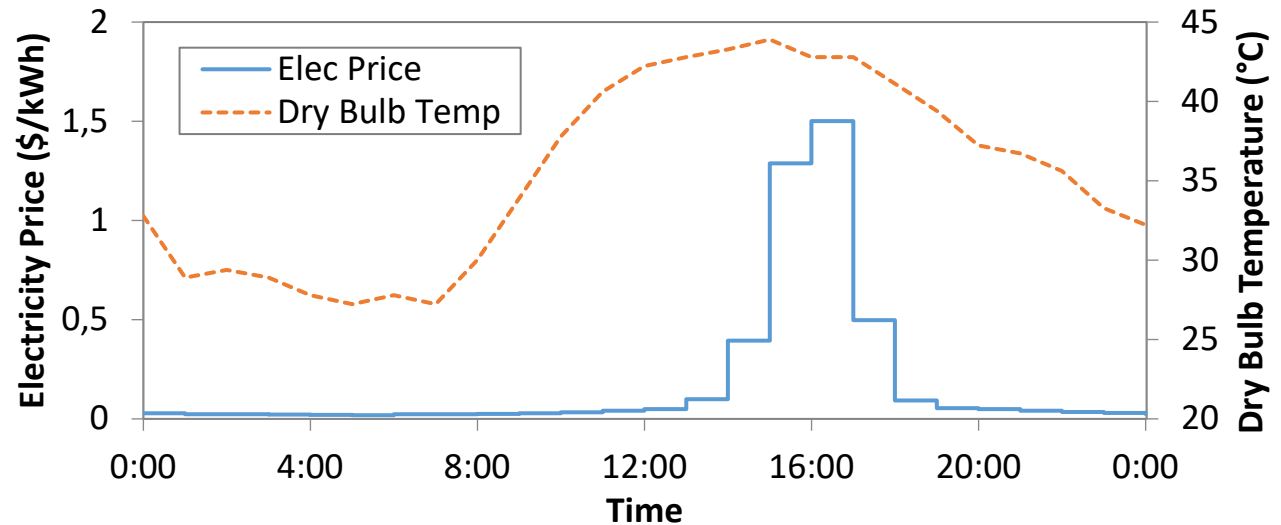
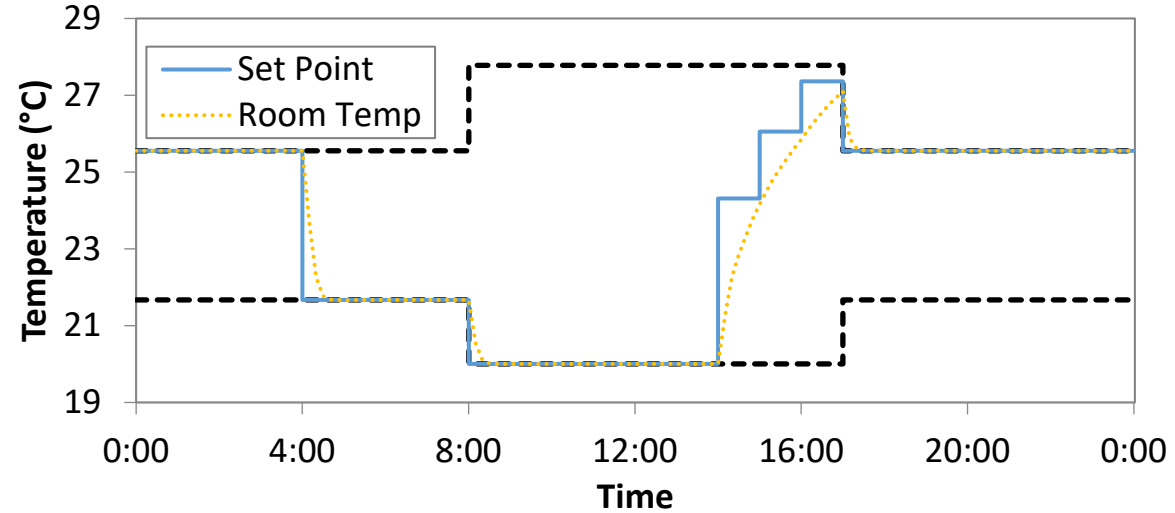

Results (Hot Summer Day)

	Base Case	Optimal Case
Total Usage	19.7 kWh	22.7 kWh
Total Cost	\$5.27	\$1.65
Peak Usage	5.7 kWh	1.4 kWh

69% Reduction in Cost

83% Reduction in Peak Energy

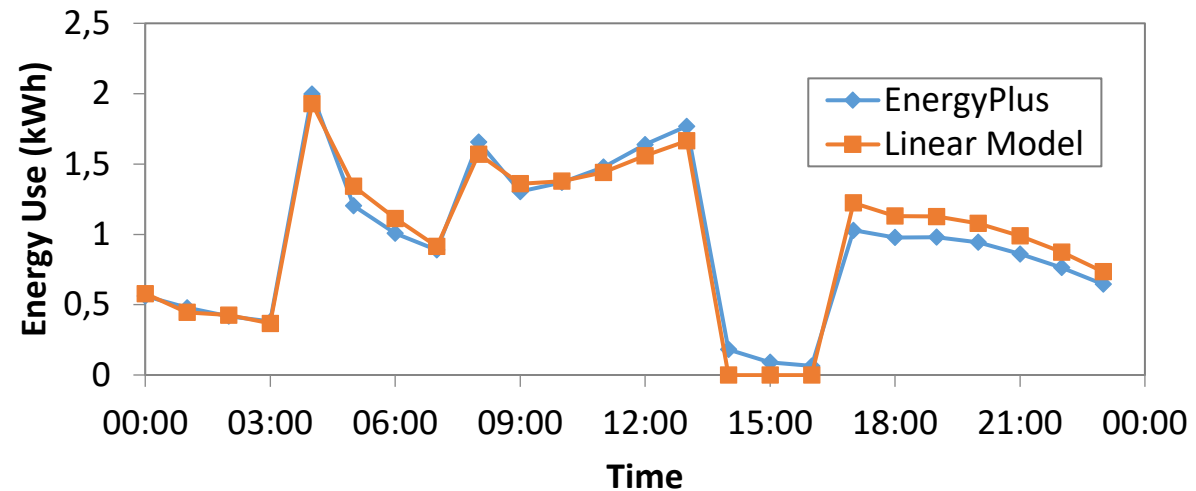
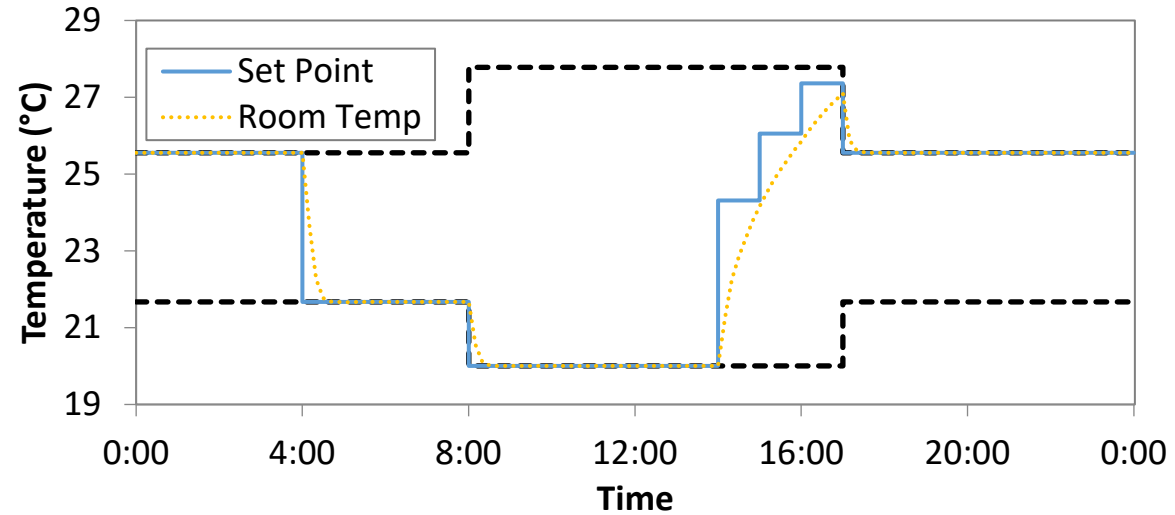

Min Cost Results (Single Home)

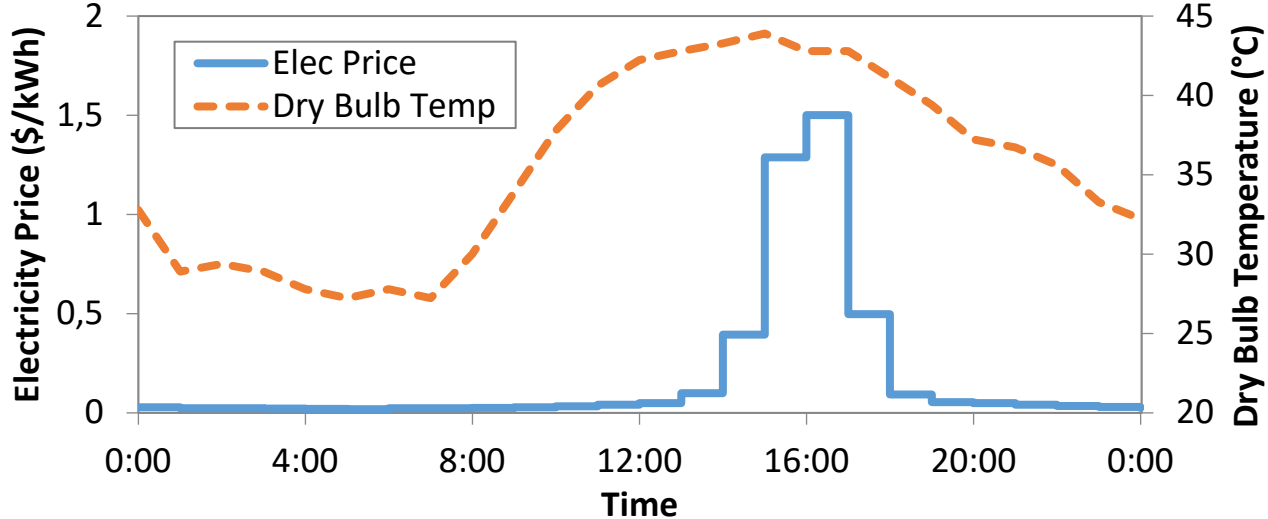
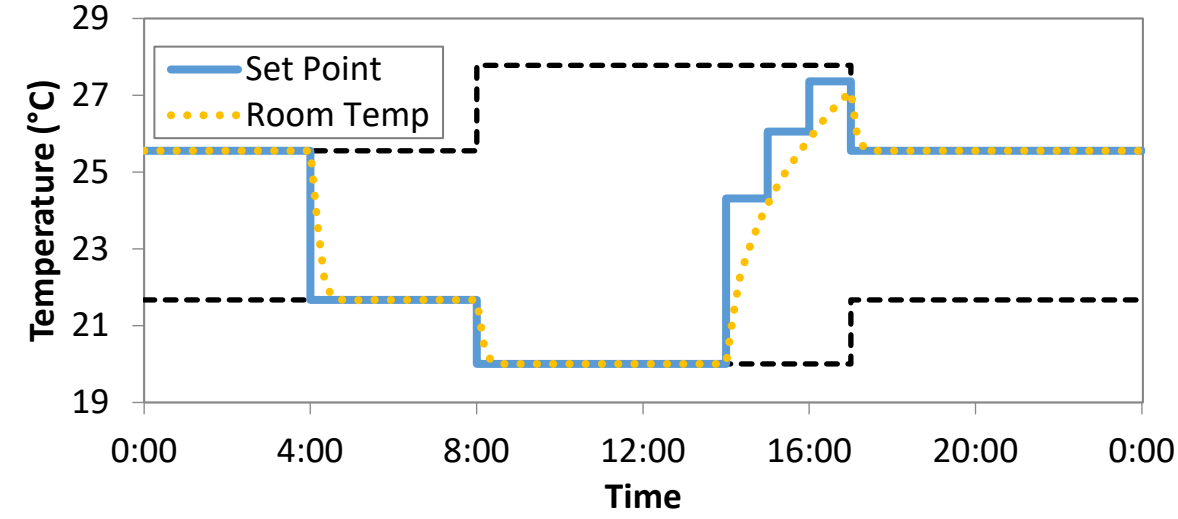

Min Peak Results (900 homes)

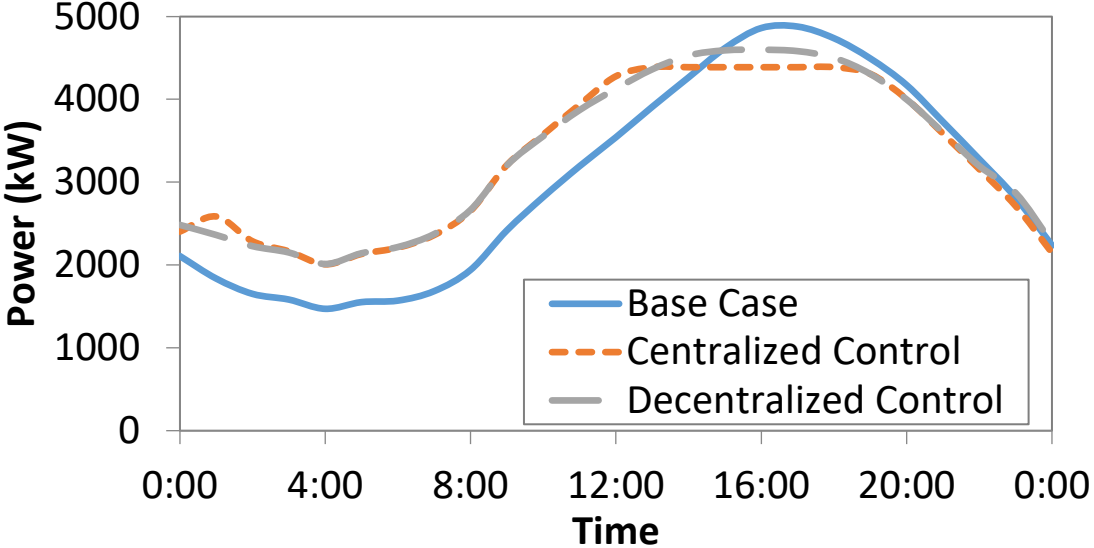

Peak Reduction:
Centralized = 10%
Decentralized = 5.7%

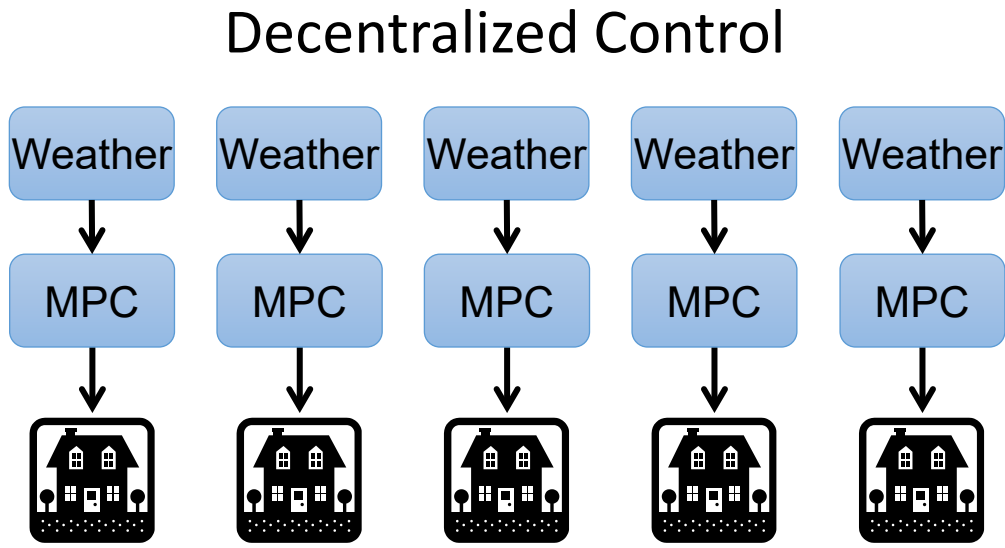
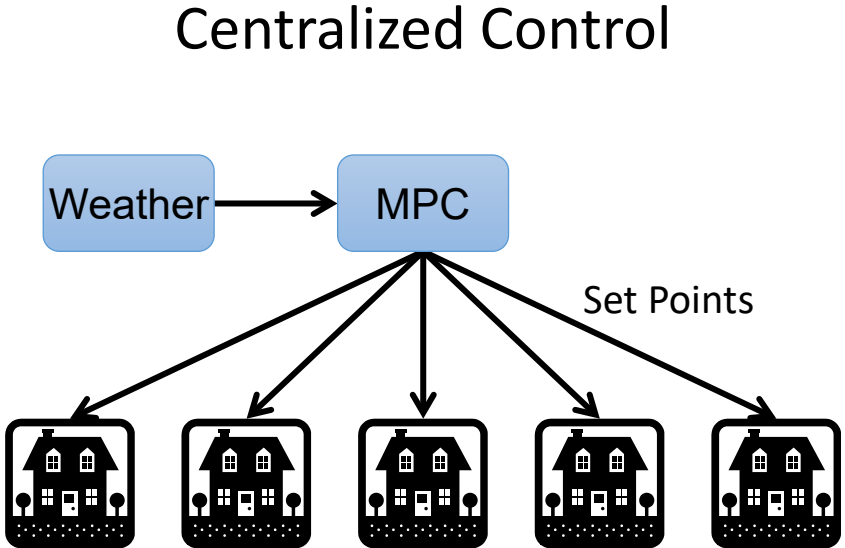

Community with Solar PV

- 3.42 kW arrays
- Mix of south facing and west facing
- Data from measurements of 226 rooftop arrays

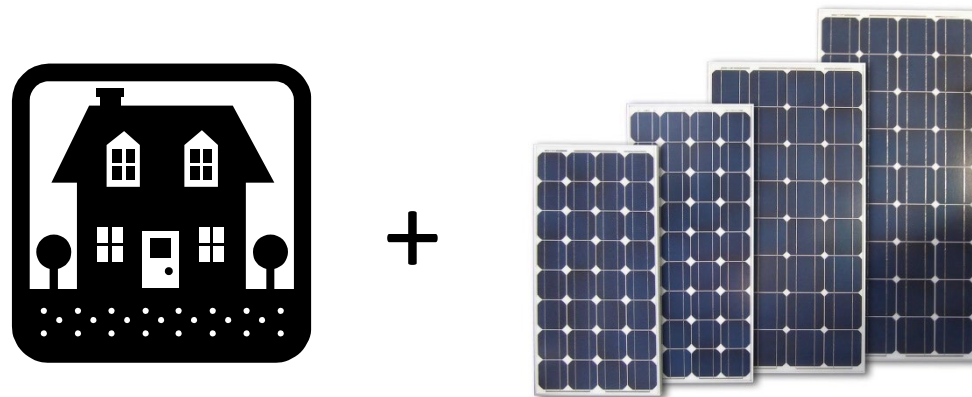

Coordinated Control with Solar PV

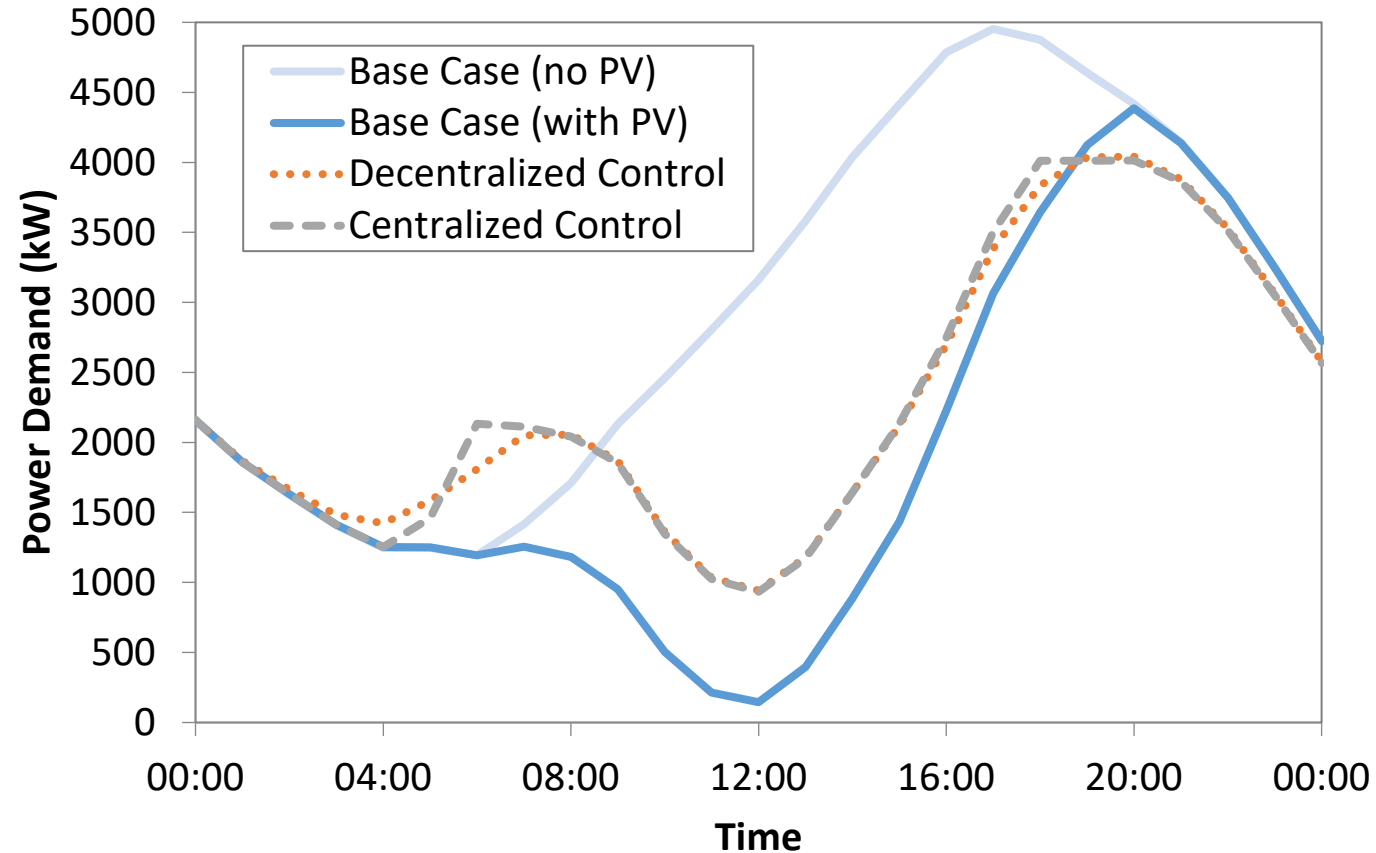

PV shifts peak

Centralized and decentralized control very similar

Battery cost projections for 4-hour lithium ion systems

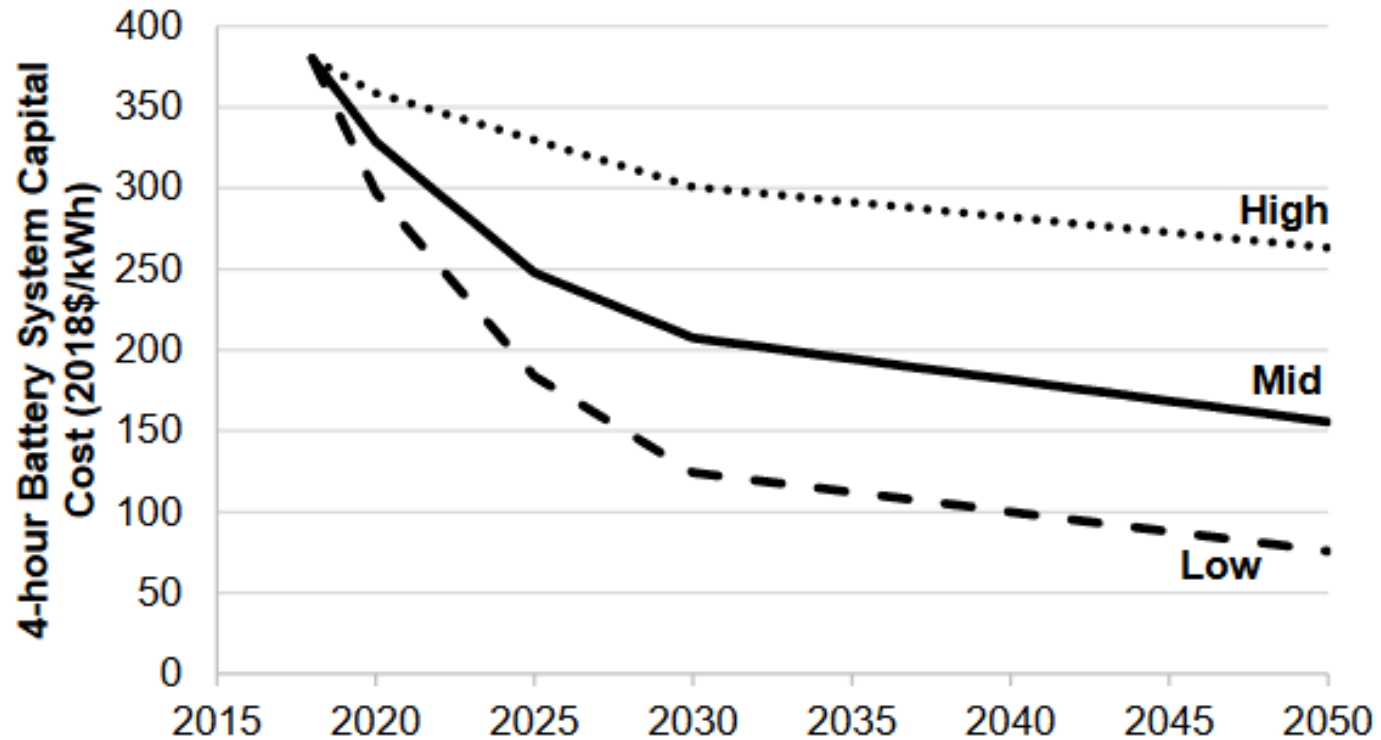

Thermal Energy Storage

- Thermal energy storage (TES) systems heat or cool a storage medium and then use that hot or cold medium for heat transfer at a later point in time.
- Using thermal storage can reduce the size and initial cost of heating/cooling systems, lower energy costs, and reduce maintenance costs. If electricity costs more during the day than at night, thermal storage systems can reduce utility bills further.
- Two forms of TES systems are currently used. The first system used a material that changes phase, most commonly steam, water or ice. The second type just changes the temperature of a material, most commonly water.

Thermal Energy Storage: A Heavy Lifter

- Energy stored as heat or cooling
- Different types and configurations
 - Sensible, latent
 - Solid, liquid, vapor, or combinations
 - “Heat things up and cool them down”
- Powerful with existing technology can be smart too
 - Low Cost
 - High Impact



Why Use TES for Space Cooling?

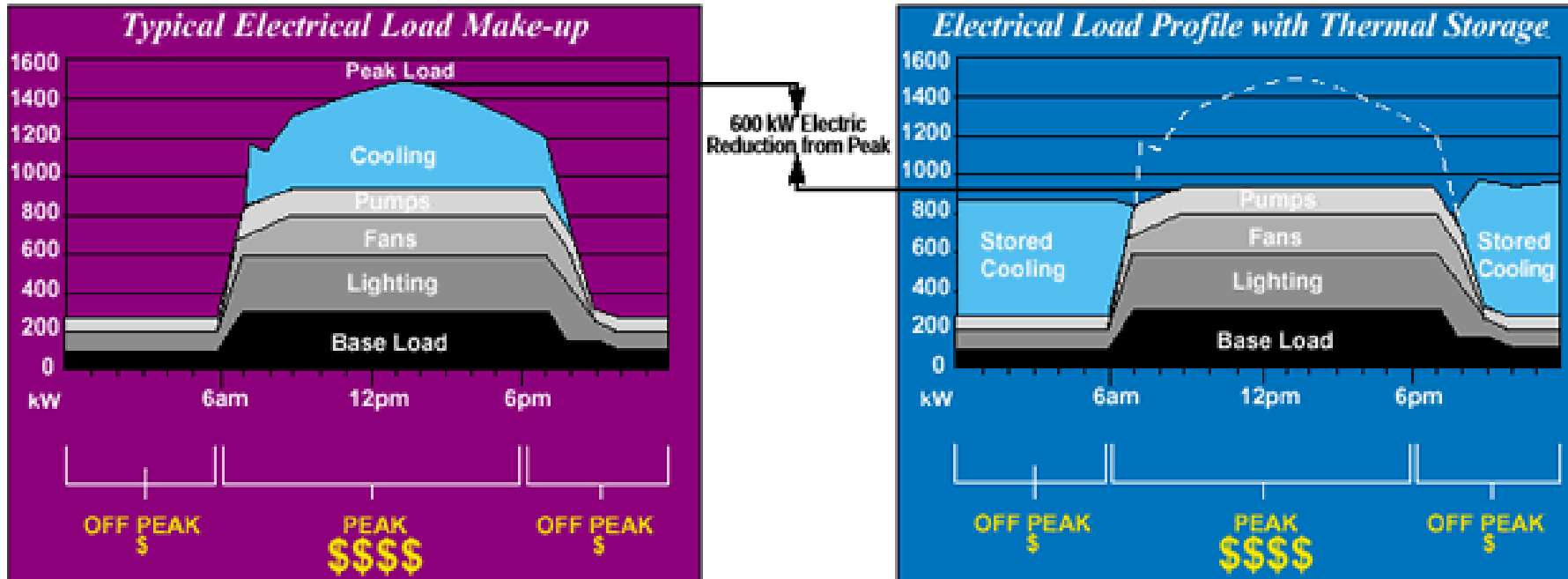

- Can also be a way to take advantage of wind power, which is more abundant at night

UT Austin – A CHP plant (80+ % efficiency) with District Cooling Network

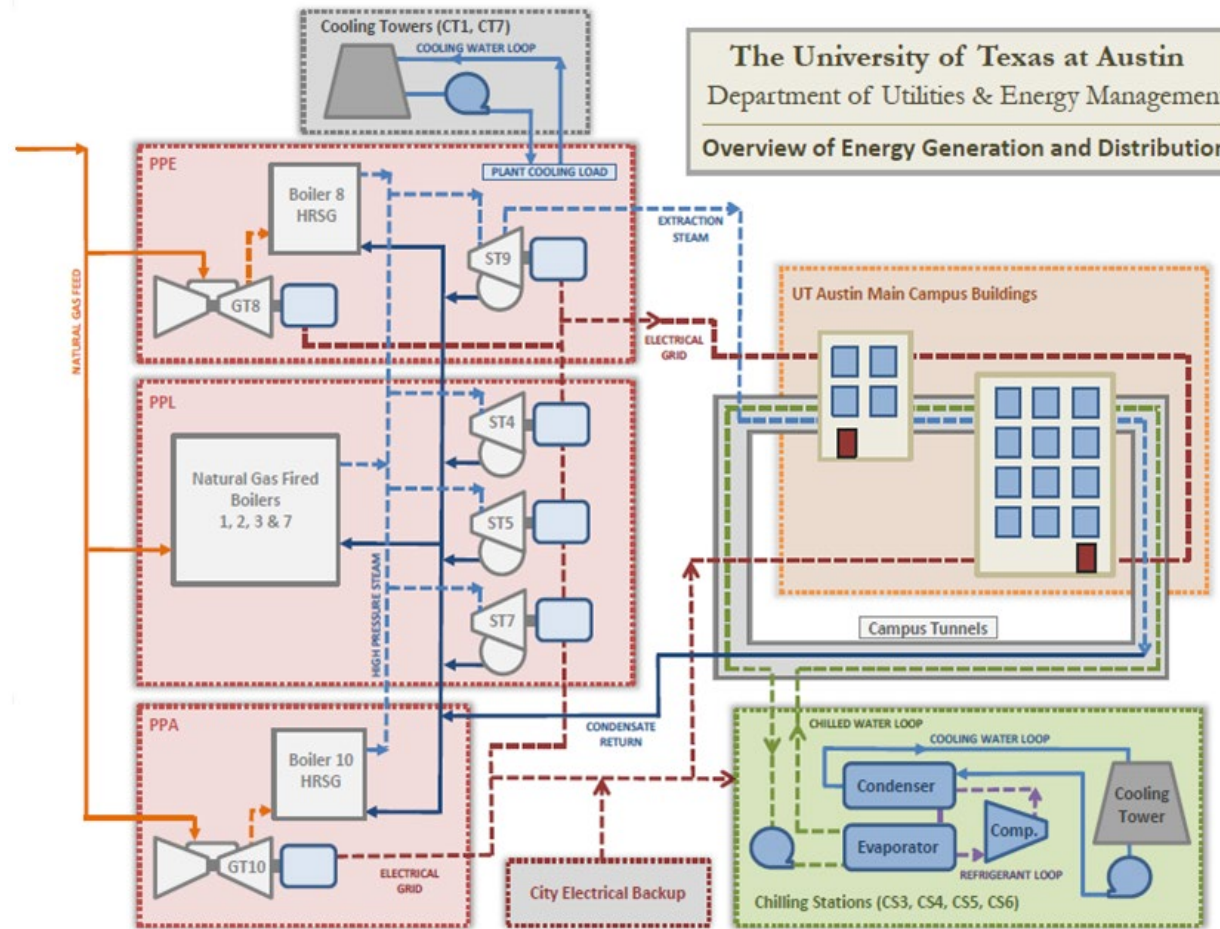

Hal C. Weaver Power Plant

District Cooling

- Chilled water network
- Economy of scale
 - Centralized chillers
 - Thermal energy storage
- Opportunity for optimal chiller loading

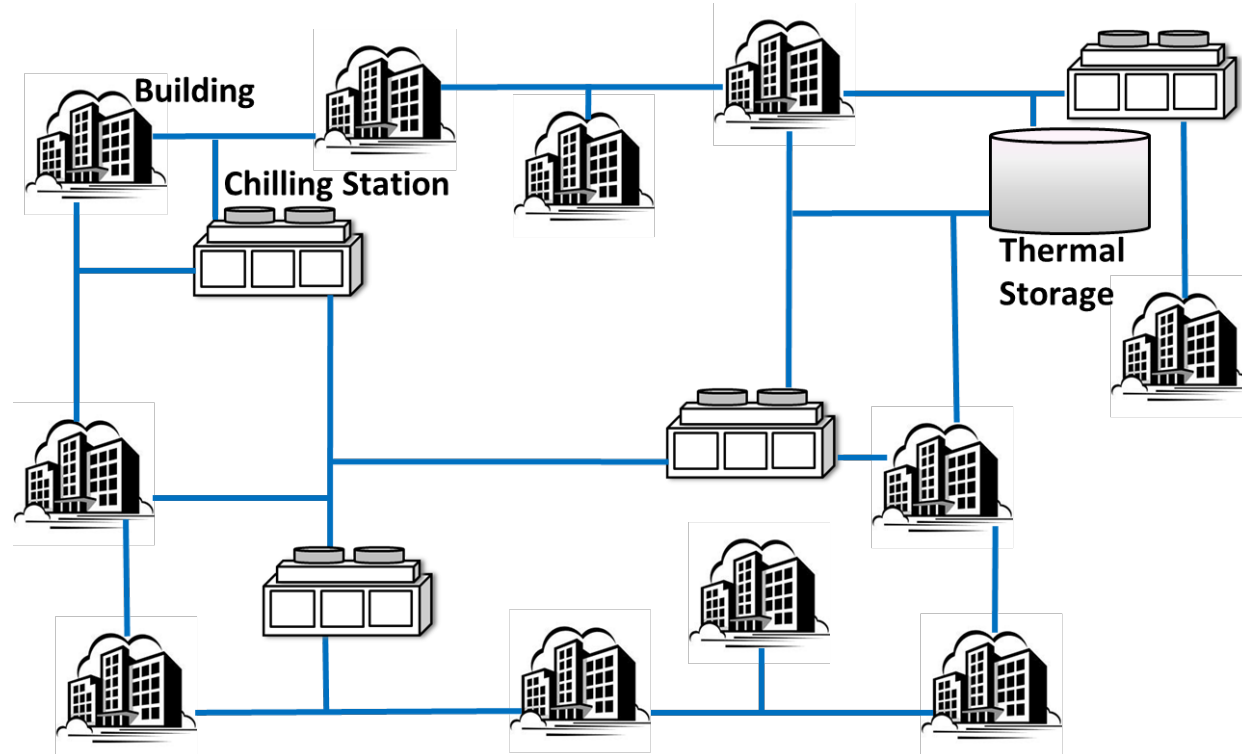

Optimal Chiller Loading to Save Energy

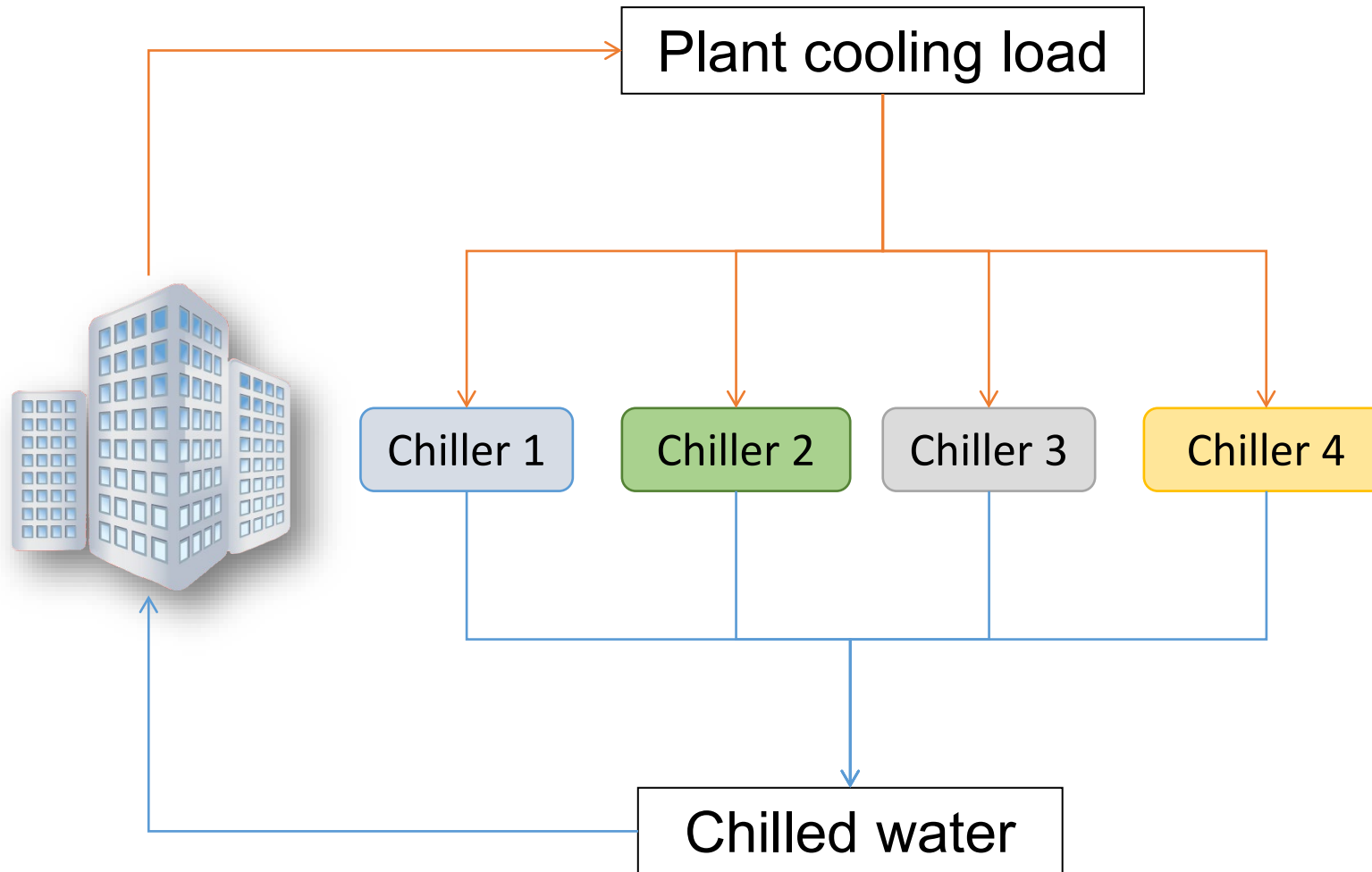

Optimal Chiller Loading

- A chiller cools the water for air conditioning
- Other energy consuming equipment in a chilling station are cooling towers and pumps
- Chillers are different from one another in terms of efficiency and/or capacity.
- Optimal chiller loading – best distribution of cooling load among chillers to minimize the power consumption
- Thermal energy storage – to store chilled water which can be used later

Thermal Energy Storage Operating Strategy with Four Chillers

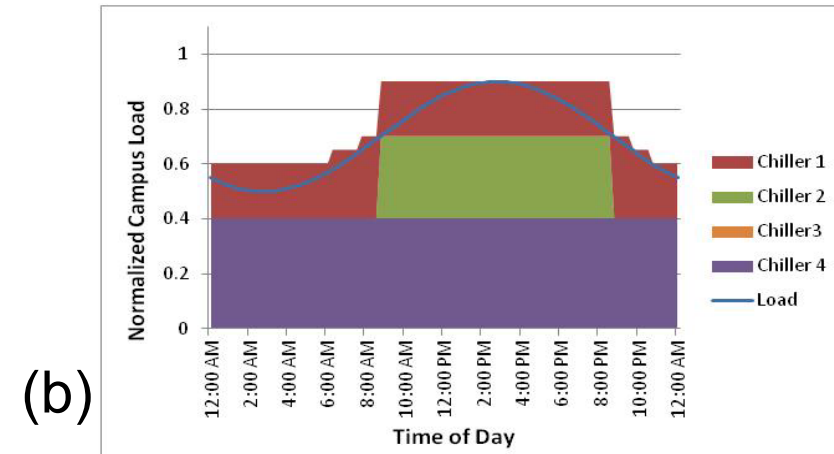
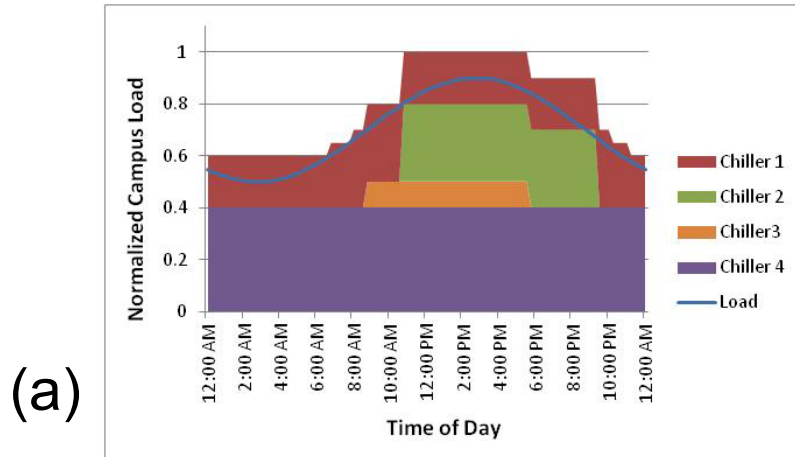

-Chillers 1& 4 are most efficient, 3 is least efficient

-Chiller 1 is variable frequency

(a) Experience-based (operator-initiated)

-No load forecasting

-Uses least efficient chiller (Chiller 3)

(b) Load forecasting + optimization

-Uses most efficient chillers (avoids Chiller 3)

(c) Load forecasting + TES + optimization

-Uses only two most efficient chillers

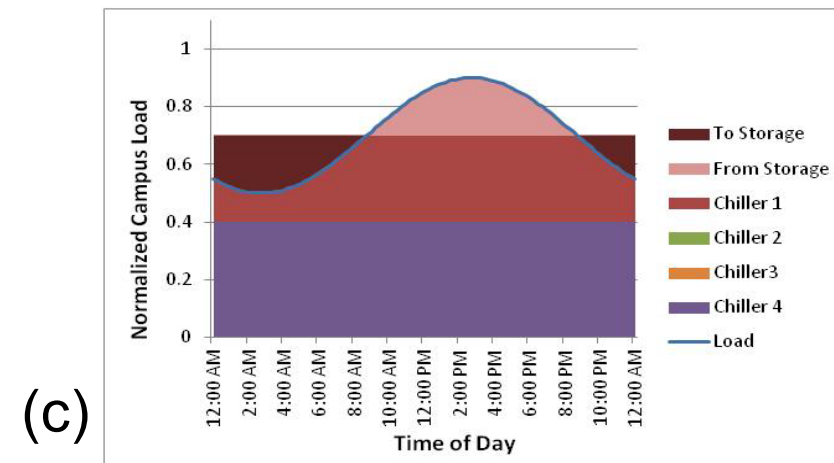

Cost Minimization Results

	Case 1	Case 2	Case 3
Equal Ratio Chiller Loading	\$23,600	\$28,600	\$39,500
Static Optimal Chiller Loading	\$21,800	\$26,500	\$37,000
Dynamic Optimal Chiller Loading	\$19,500	\$23,900	\$34,500
Total Savings	17.4%	16.4%	12.7%

- Time-of-Use Pricing
 - \$0.1/kWh off peak
 - \$0.2/kWh on peak
- Up to 17.4% savings

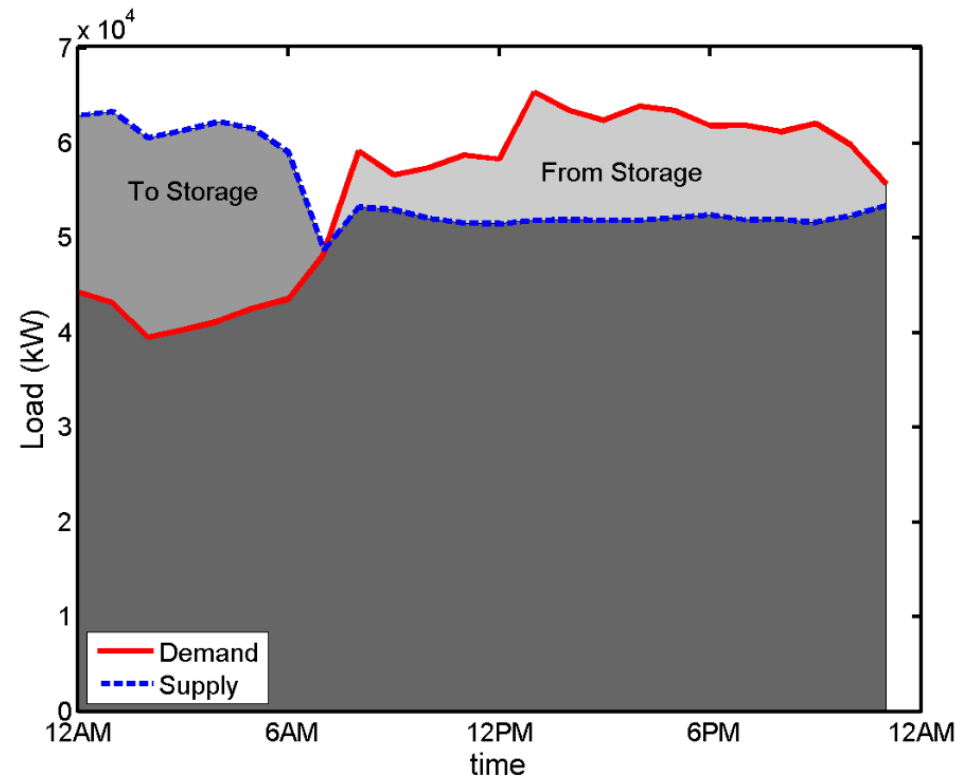



TES with Concentrated Solar Power (CSP)

- CSP technologies concentrate sunlight to heat a fluid and run a generator

- By coupling CSP with TES, we can better control when the electricity is produced

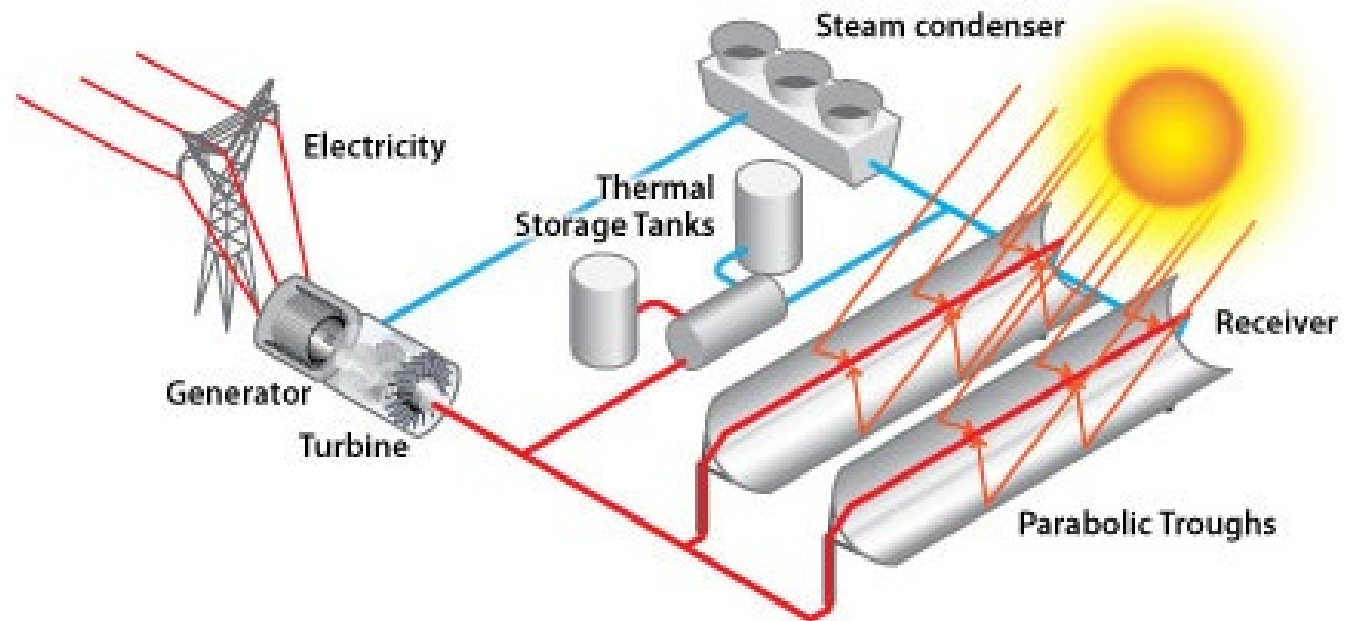

Control Strategy

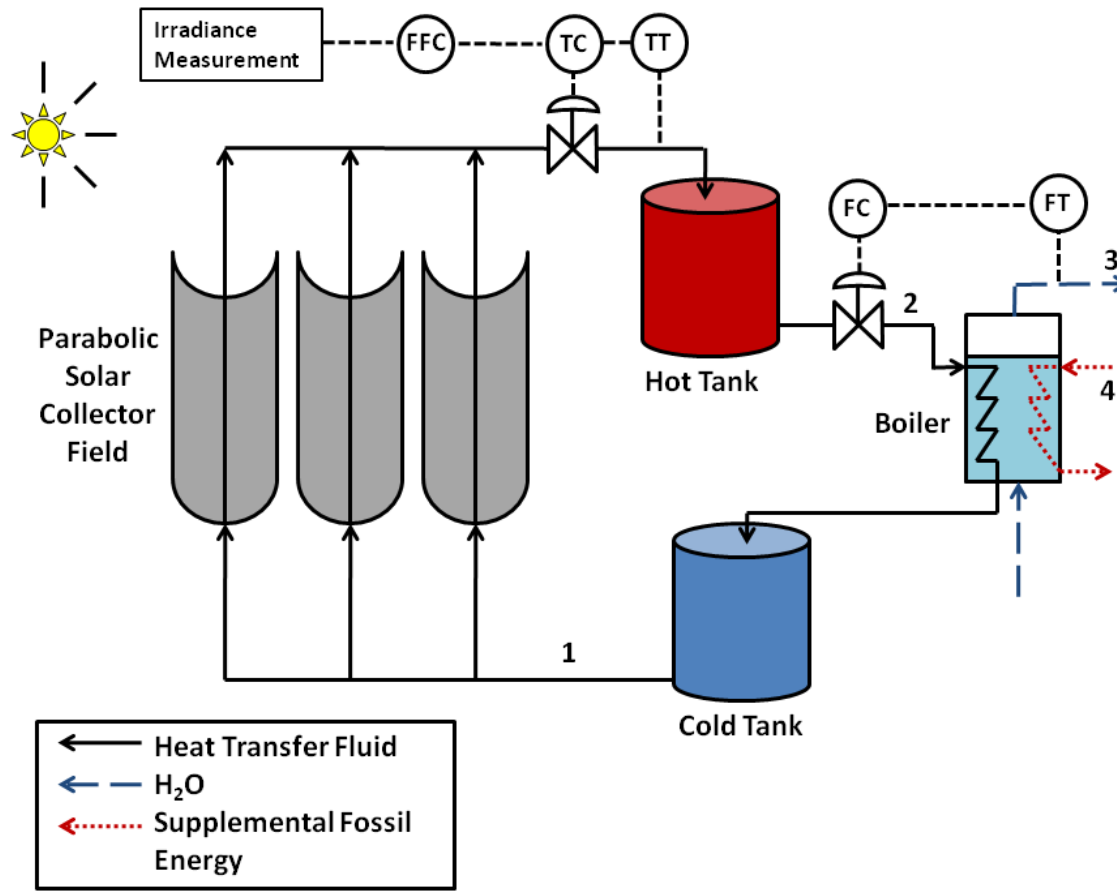

- Feedforward + Feedback (PID) temperature control
 - Uses FF measurements of solar irradiance
 - Flow rate of stream 1 is manipulated variable
- Feedback control (PID) used for steam flow (power) control
- Supplemental gas used when solar energy is not sufficient (stream 4)

Storage Tank Model

Mass Balance

$$\rho_{HTF} \frac{dV}{dt} = \dot{m}_{in} - \dot{m}_{out}$$

$$V_{Cold}(t=0) = V_{High}$$

$$V_{Hot}(t=0) = V_{Low}$$

Energy Balance

$$\rho_{HTF} C_{HTF} \frac{d(VT)}{dt} = C_{HTF}(T_{in}\dot{m}_{in} - T\dot{m}_{out}) - UA(T - T_{AIR})$$

$$T_{Cold}(t=0) = T_{Cold,0}$$

$$T_{Hot}(t=0) = T_{Hot,0}$$

Boiler Model

Energy Balances:

Heat Transfer Fluid

$$\rho_{HTF} C_{HTF} A_{pipe,i} \frac{\partial T_{HTF}}{\partial t} = \dot{m} C_{HTF} \frac{\partial T_{HTF}}{\partial x} + h_{pipe} P_{pipe,i} (T_{Boiler} - T_{HTF})$$

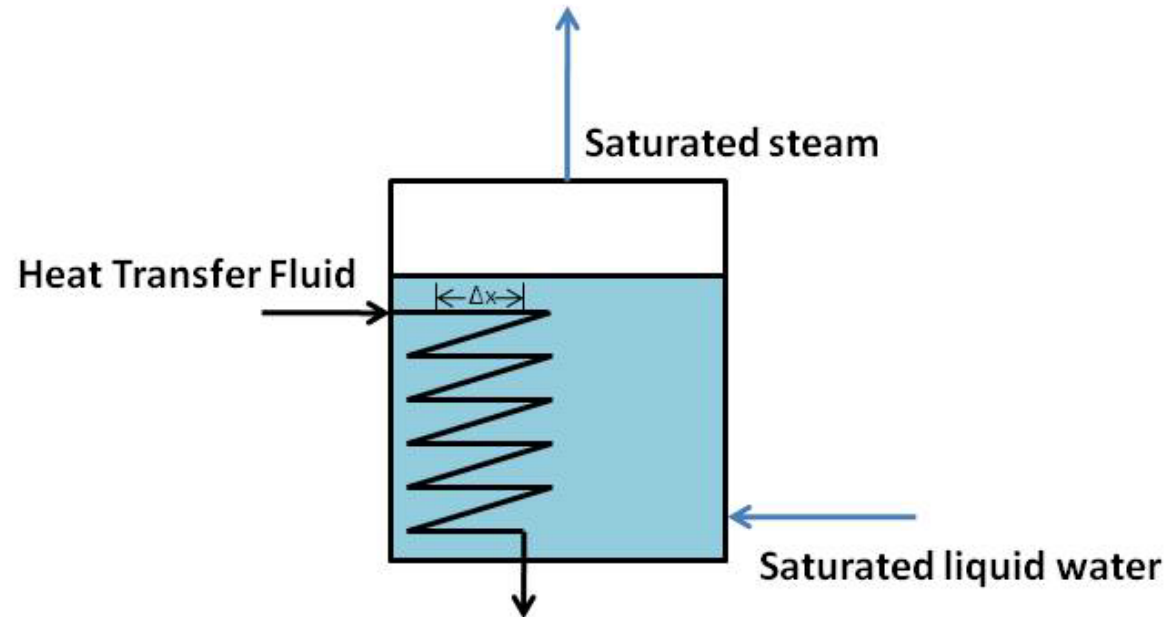

Boiler

$$\dot{m}_{HTF} C_{HTF} (T_{HTF,in} - T_{HTF,out}) = \dot{m}_{steam} h_{fg}$$

Solar Energy and the Need for Storage

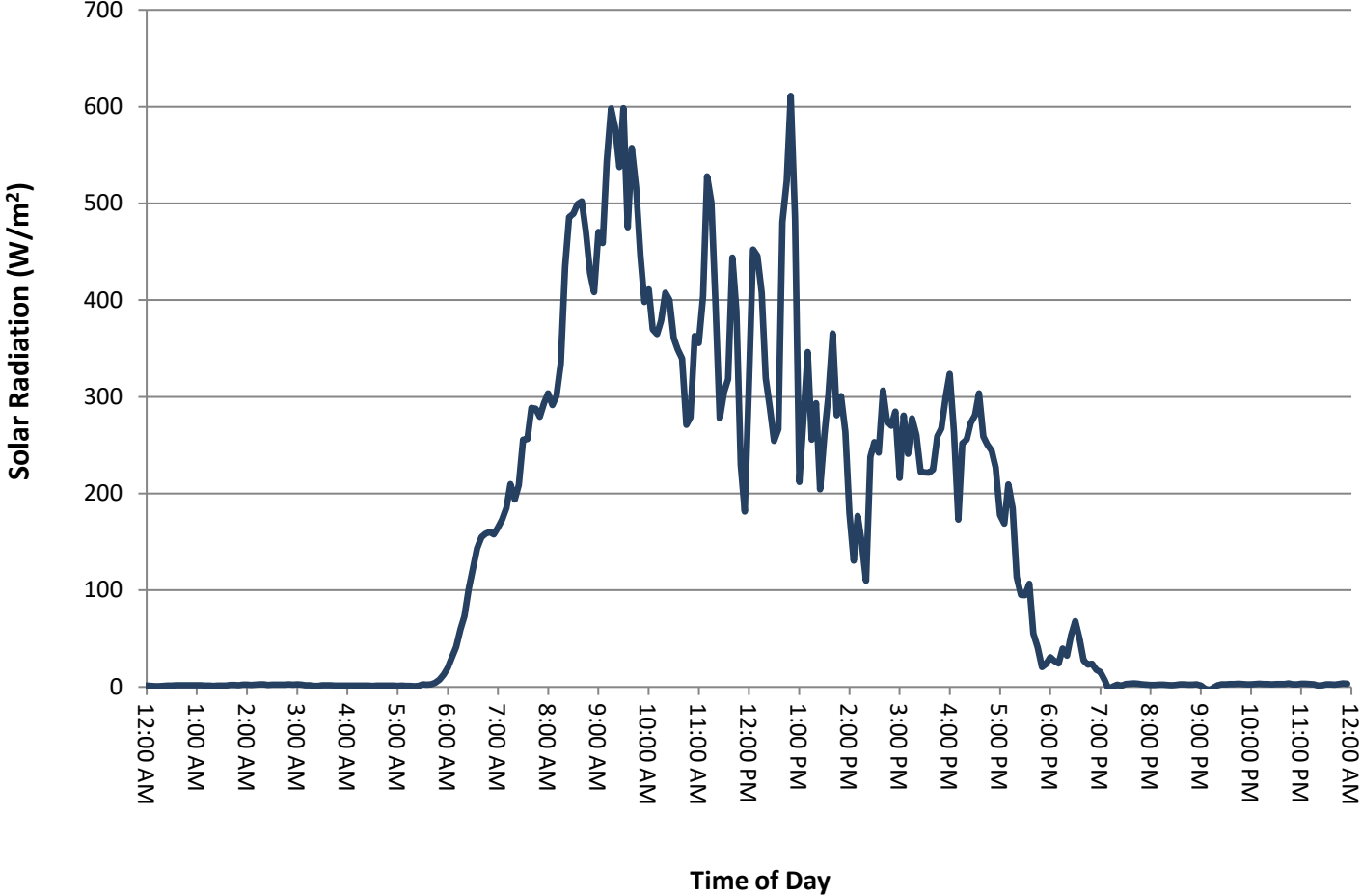

Results: Sunny Day, System without Storage (No Power Control)

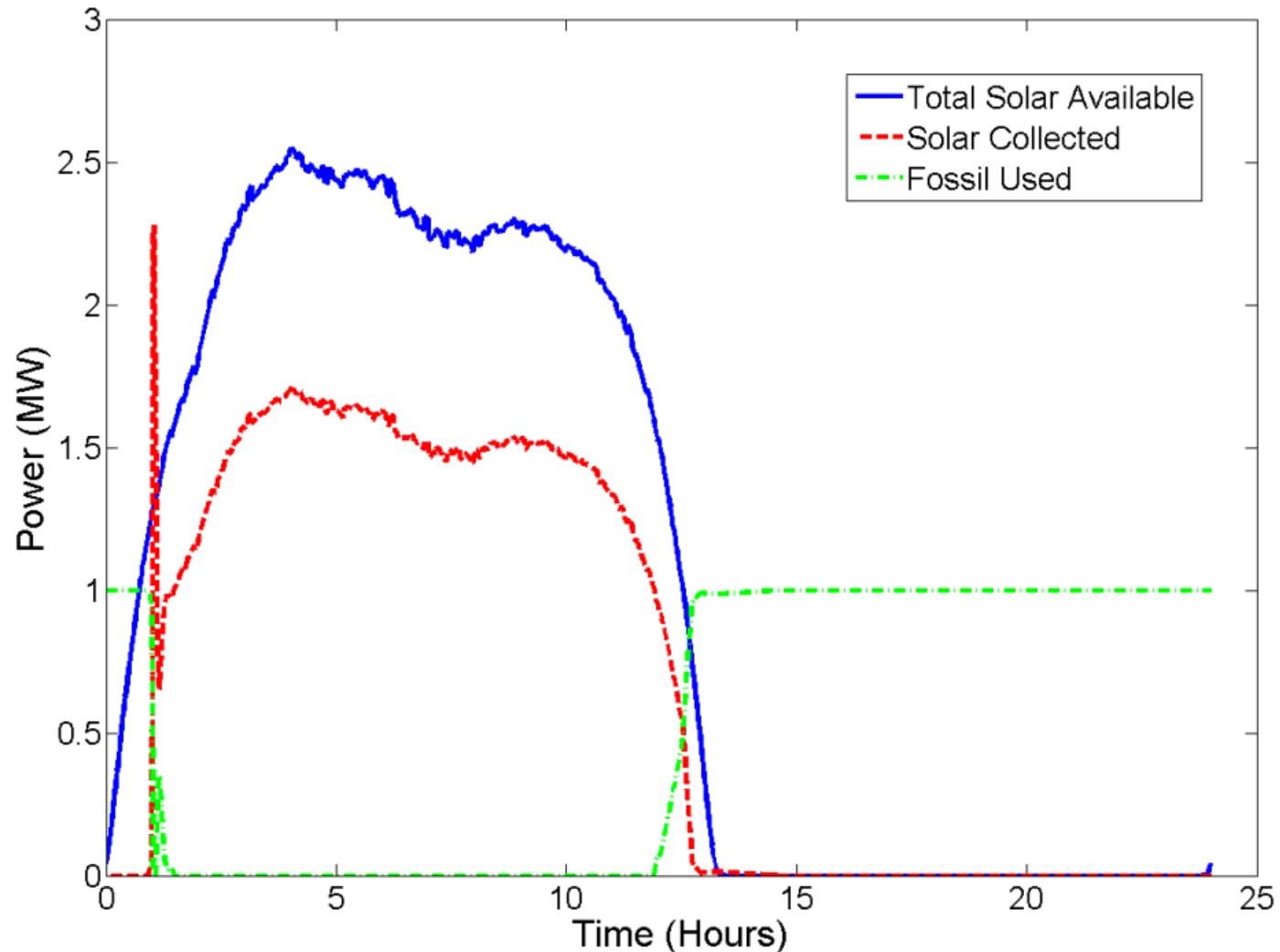

Results: Sunny Day, System with Storage and Power Control

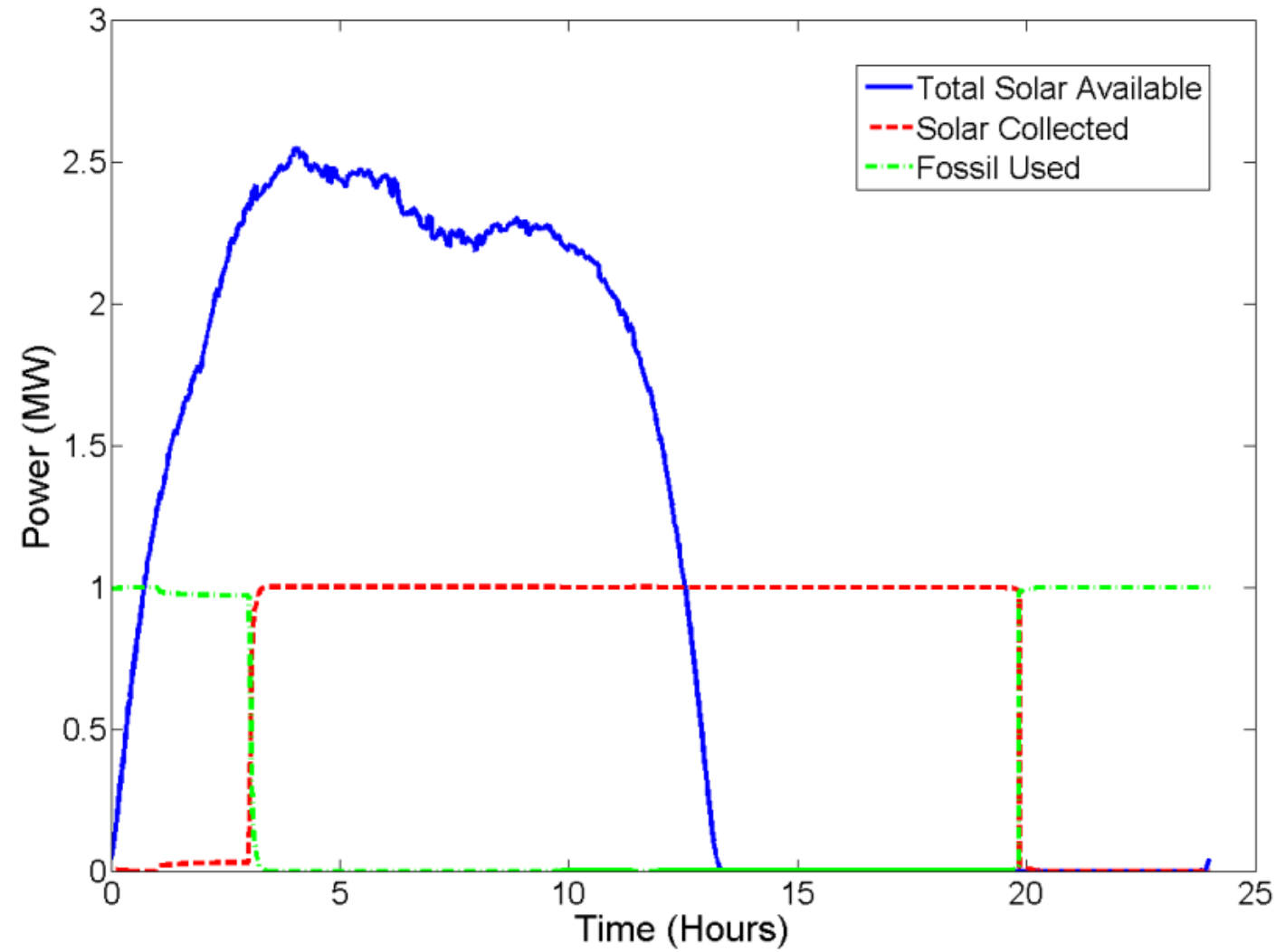

Results: Cloudy Day, System without Storage (No Power Control)

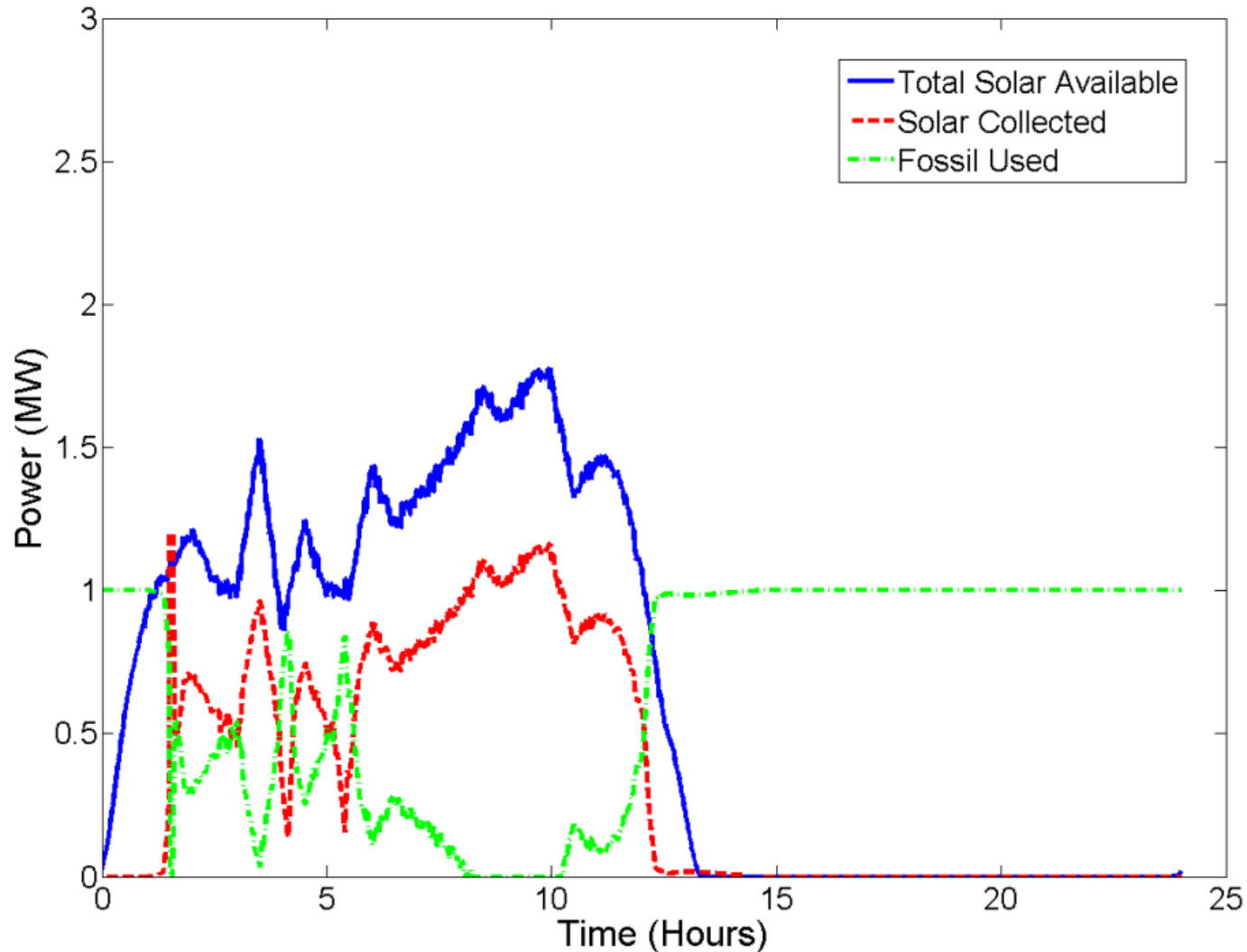

Results: Cloudy Day, System with Storage and Power Control

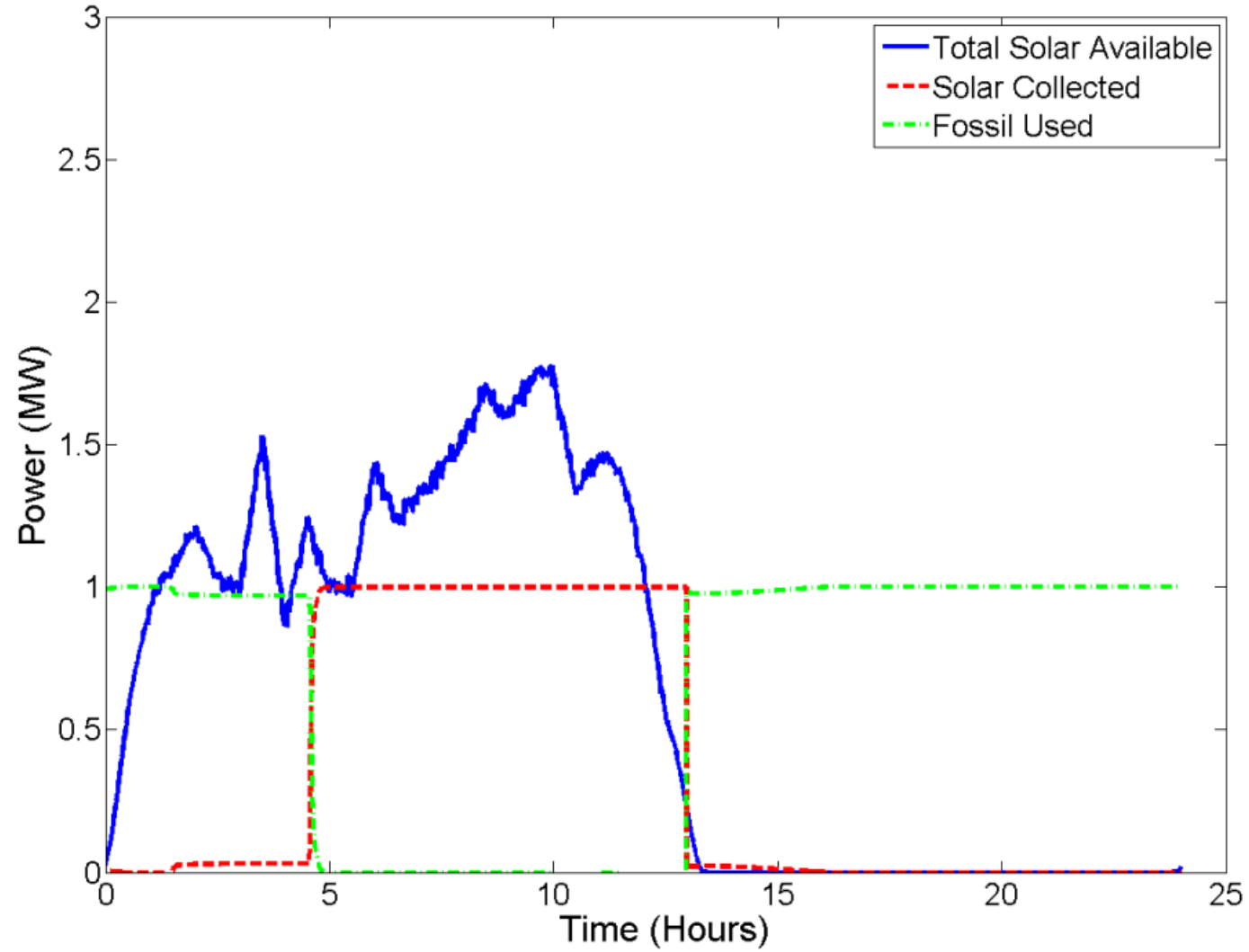

Summary of Results

	Sunny Day: System without Storage	Sunny Day: System with Storage	Cloudy Day: System without Storage	Cloudy Day: System with Storage
Solar Energy Delivered to Load	16.48	16.82	8.40	8.49
Supplemental Fuel Required (MWh)	12.58	7.18	15.78	15.51
Solar Share	47.6%	70.1%	34.3%	35.4%

- Solar Share increased by 47% on sunny day, 3% on Cloudy day
- Power quality much better with storage
- Dynamic optimization with weather forecasts can further improve solar share

Energy Matrix with Heat Storage

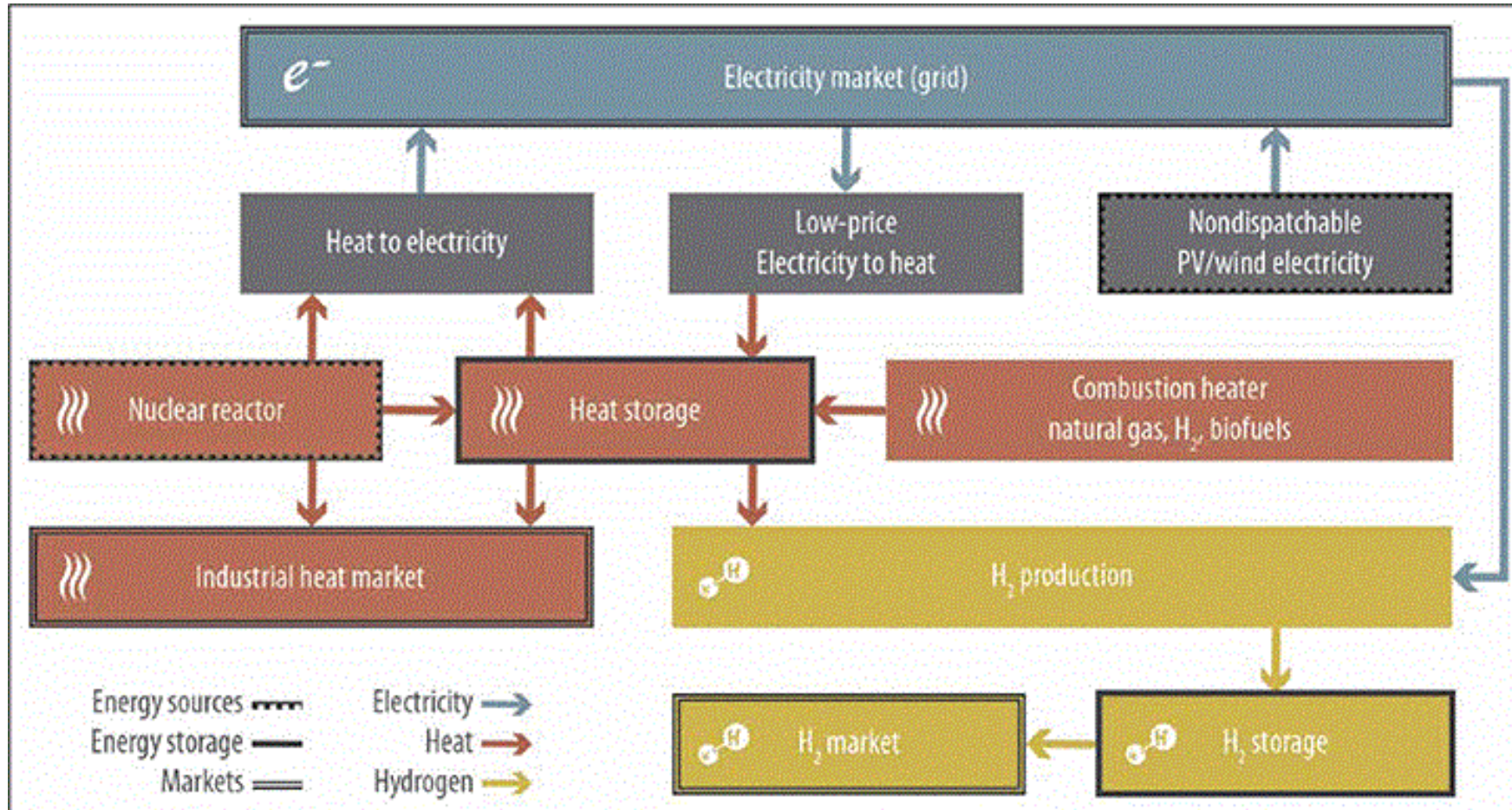

(Forsberg and Bragg-Sitton, 2020)

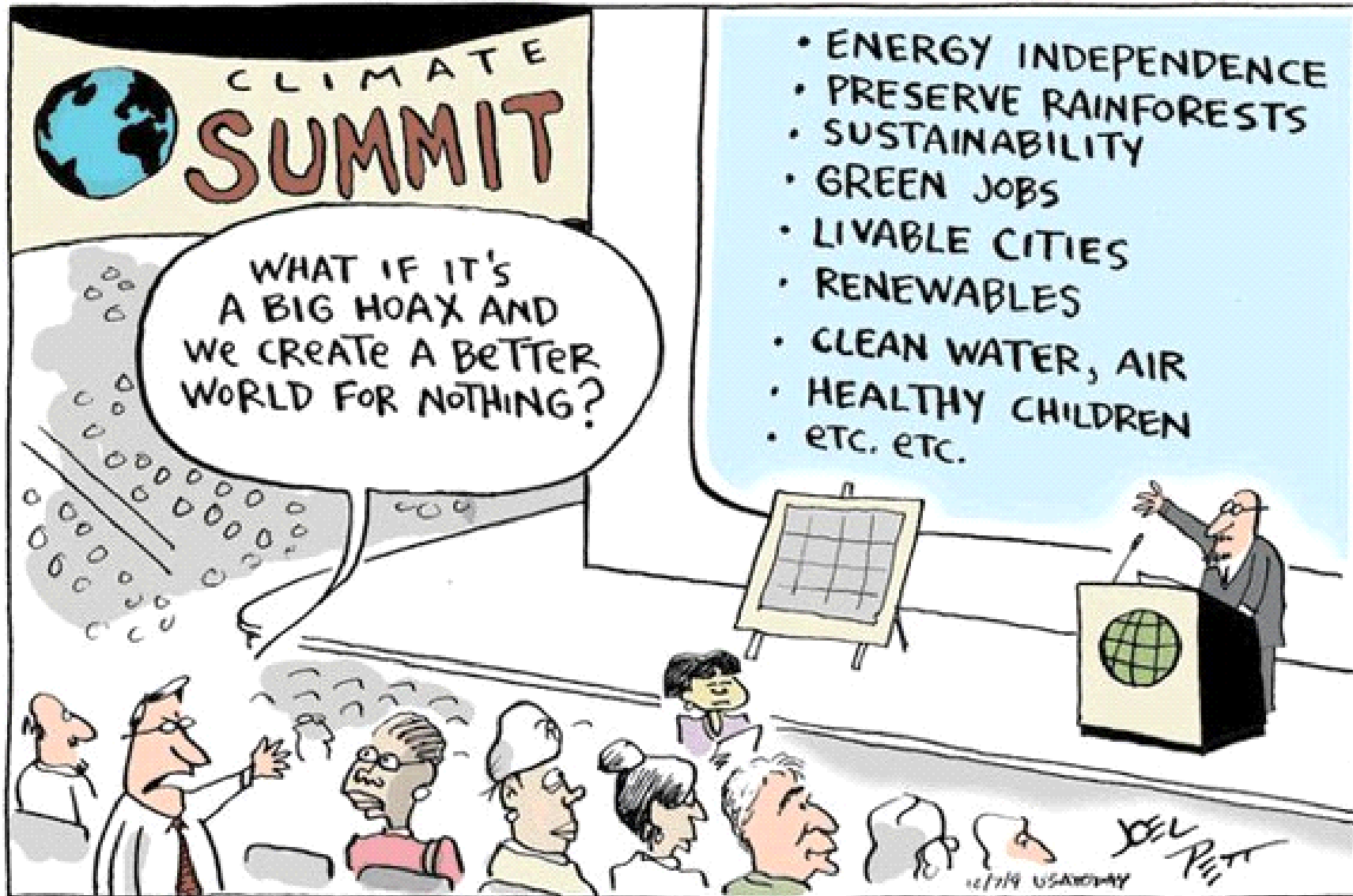

- ENERGY INDEPENDENCE
- PRESERVE RAINFORESTS
- SUSTAINABILITY
- GREEN JOBS
- LIVABLE CITIES
- RENEWABLES
- CLEAN WATER, AIR
- HEALTHY CHILDREN
- ETC. ETC.

WHAT IF IT'S
A BIG HOAX AND
WE CREATE A BETTER
WORLD FOR NOTHING?

Seasonal Thermal Energy Storage

Drake Landing Solar Community (Okotoks, Alberta, Canada)

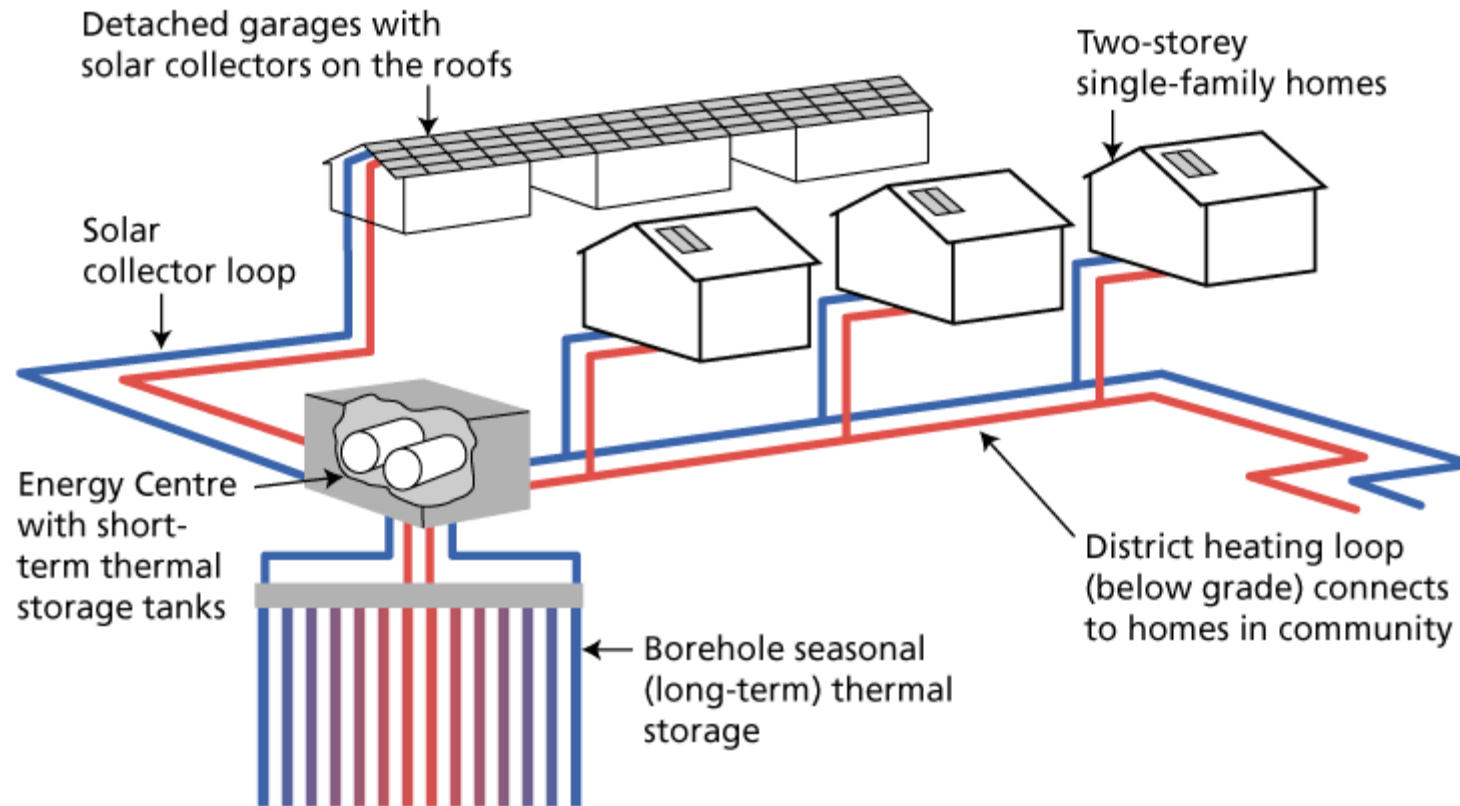

Annual Energy Savings at Drake Landing

Energy Consumption Comparison

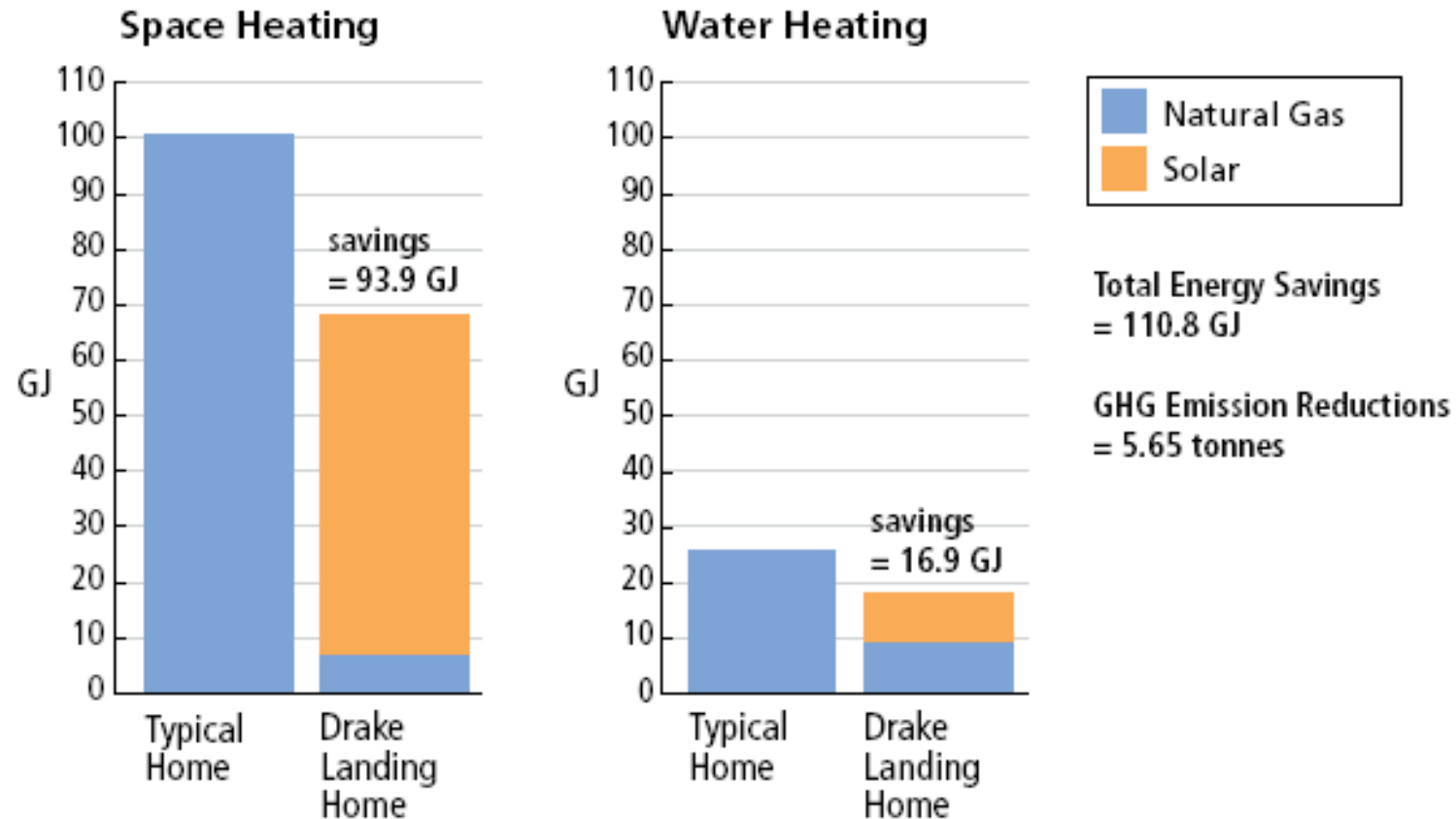

Minimization of the nonrenewable energy consumption in bioethanol production processes using a solar-assisted steam generation system

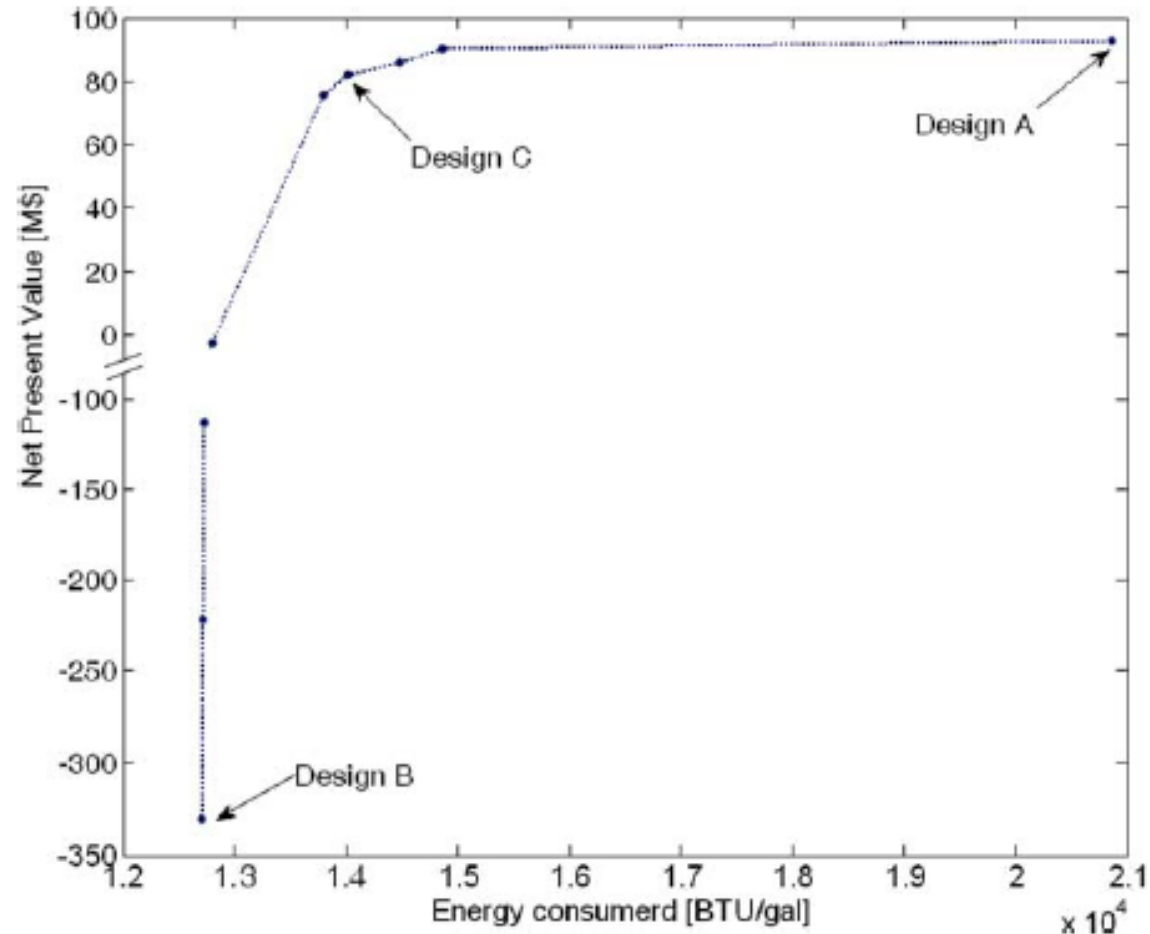

Figure 3. Pareto set of optimal solutions in the bioethanol production plant

Table 5. Economic and Energetic Summary of the Bioethanol Process

Item	Design A	Design B	Design C
Net Present Value (\$)	92,752,281	-328,817,003	75,610,887
Energy consumed (Btu/gal)	20,968	12,838	13,903
Total Capital Investment (\$)	37,159,397	316,441,020	44,862,192
Operating Cost (\$/yr)	63,021,995	79,893,062	62,606,124
Production Rate (kg/ yr)	119,171,463	119,171,463	119,171,463
Unit Production Cost (\$/kg)	0.67	1.12	0.68
Unit Selling Price (\$/kg)	0.69	0.69	0.69
Total revenues(\$)	81,826,000	81,826,000	81,826,000
Area solar panels (m ²)	0	5,430,794	71,053
Natural gas consumed (kg/yr)	22,066,980	10,570,180	12,102,040

AICHE Journal

Brunet, Robert, Gonzalo Guillén-Gosálbez, and Laureano Jiménez. "Minimization of the nonrenewable energy consumption in bioethanol production processes using a solar-assisted steam generation system." *AICHE Journal* 60.2 (2014): 500-506.

World Energy Perspective (cf. 2020 Davos, COP 26)

- Oil and gas demand globally remains robust, but large oil companies may shift long-term investments away from oil and gas production
- Coal will remain a critical part of the global energy mix(due to Asian coal plants with average age of 12 years)
- Ammonia and hydrogen may supplant some oil production even in the Middle East
- Industry needs to take steps to reduce the emissions that come from producing and delivering oil and gas to consumers
- A decarbonized world will require more regionally-generated electricity, especially in USA and Europe

Conclusions

- Consumer preferences (stockholders, states, cities) as well as power plant economics are driving the reduction in grid carbon emissions
- Energy efficiency = sustainability(reduced carbon footprint)
- Greater than 80% renewables is not practically feasible due to their intermittent nature(but economical storage will help)
- Future increase in electrical vehicles will increase reliance on the grid
- Systems dynamics and optimization will play an increasing role in maximizing efficiency while minimizing carbon emissions over many time scales

THANK YOU.

Thomas F. Edgar, Abell Chair Emeritus

tfedgar@austin.utexas.edu

www.che.utexas.edu



The University of Texas at Austin
McKetta Department
of Chemical Engineering
Cockrell School of Engineering